



## **GUIDANCE MATERIAL**

### **PAVEMENTS 34 GM- 09**

**June 2026**



**Table of Contents**

REFERENCES .....	5
Definitions.....	6
Abbreviations and Acronyms.....	8
Chapter 1 .....	9
PROCEDURES FOR REPORTING AERODROME PAVEMENT STRENGTH .....	9
1.1 Procedures for Pavements Meant for Heavy Aircraft (Aircraft Classification Rating —Pavement Classification Rating (ACR-PCR) Method) .....	9
Chapter 2.....	48
GUIDANCE FOR OVERLOAD OPERATIONS .....	48
2.1 CRITERIA SUGGESTED IN ANNEX 14, VOLUME I, ATTACHMENT A.....	48
Chapter 3 .....	50
STRUCTURAL EVALUATION OF PAVEMENTS .....	50
3.1 GENERAL.....	50
3.2 ELEMENTS OF PAVEMENT EVALUATION.....	50
3.3 ELEMENTS OF THE ACR-PCR METHOD.....	52
3.4 ASSESSING THE MAGNITUDE AND COMPOSITION OF TRAFFIC.....	56
3.5 TECHNIQUES FOR “USING AIRCRAFT” EVALUATION .....	58
3.6 TECHNIQUES AND EQUIPMENT FOR “TECHNICAL” EVALUATION.....	62
Chapter 4.....	79
STATE PRACTICES FOR DESIGN AND .....	79
EVALUATION OF PAVEMENTS .....	79
4.1 PURPOSE .....	79
4.2 PRACTICE OF FRANCE .....	79
4.3 PRACTICE OF THE UNITED KINGDOM .....	81
4.4 PRACTICE OF THE UNITED STATES.....	82
Chapter 5 .....	85
Page intentionally left blank .....	85
Chapter 6 .....	86
Page intentionally left blank .....	86
Chapter 7 .....	87
CONSIDERATIONS FOR CULVERTS, BRIDGES .....	87
AND OTHER STRUCTURES .....	87
7.1 PURPOSE .....	87
7.2 GENERAL.....	87



7.3 DESIGN CONSIDERATIONS .....87

Chapter 8.....90

Page intentionally left blank .....90

Chapter 9.....91

STRUCTURAL CRITERIA FOR NATURAL GROUND .....91

9.1 INTRODUCTION .....91

9.2 DESIGN BACKGROUND.....91

9.3 DESIGN DETAILS .....92

9.4 GUIDANCE FOR BEARING STRENGTH OF PREPARED NATURAL GROUND AREAS .....94

Appendix 1 .....95

AIRCRAFT CHARACTERISTICS AFFECTING .....95

PAVEMENT BEARING STRENGTH .....95

Appendix 2.....108

USER INFORMATION FOR THE.....108

ICAO-ACR COMPUTER PROGRAMME.....108

Appendix 3.....116

DAMAGE MODEL FOR FLEXIBLE ACR.....116

Appendix 4.....121

Page intentionally left blank .....121

Appendix 5.....122

Page intentionally left blank .....122

Appendix 6.....123

PAVEMENT OPERATIONS AND MAINTENANCE.....123

RELATED GUIDANCE .....123



## FOREWORD

This Guidance material- provides guidance on the design of pavements, including their characteristics, and on evaluating and reporting on their bearing strength. The material included herein is closely associated with the specifications contained JCAR Part 14 — *Aerodromes*, The purpose of this Guidance material is to encourage the uniform application of those specifications and to provide information and guidance.

This Guidance Material has been developed to support the implementation of JCAR Part 14 requirements in the Hashemite Kingdom of Jordan. While certain references to international ‘State practices’ are included for benchmarking, this document shall be applied under the authority of CARC.

This guidance material contain the following:

- (a) up-to-date information on the ACR-PCR method for reporting pavement bearing strength (Chapter 1);
- (b) up-to-date material on regulating overload operations in accordance with the use of the ACR-PCR method (Chapter 2);
- (c) up-to-date material on the evaluation of pavements (Chapter 3);
- (d) up-to-date material on States’ practices for the design and evaluation of pavements provided by France, the United Kingdom and the United States.
- (e) up-to-date material on runway surface texture and drainage characteristics
- (f) up-to-date guidance on protection of asphalt pavements
- (g) up-to-date material on structural design considerations for culverts and bridges
- (h) up-to-date material on the construction of pavement overlays during operations closures
- (i) new material on the bearing strength of natural ground areas
- (j) new landing gear designation system and updated main aircraft characteristics affecting pavement bearing strength
- (k) user information for the ICAO-ACR computer programme (Appendix 2);
- (l) details on the damage model for flexible ACR (Appendix 3);
- (m) pavement operations and maintenance oriented guidance (new Appendix 6).

**REFERENCES**

- JCAR Part (139) — Aerodrome Certification and Operations.
- JCAR Part (14) — Aerodrome Design and Operations.
- ICAO Airport Design Manual Doc 9157 part 3 pavements.



**Captain Daifallah Alfarajat**  
**Chief Commissioner / CEO**

## Definitions

**Aggregate.** General term for the mineral fragments or particles which, through the agency of a suitable binder, can be combined into a solid mass, e.g., to form a pavement.

**Aircraft classification number (ACN).** A number expressing the relative effect of an aircraft on a pavement for a specified standard subgrade strength.

**Aircraft classification rating (ACR).** A number expressing the relative effect of an aircraft on a pavement for a specified standard subgrade strength.

**All-up mass.** Aircraft maximum ramp or taxi mass, also referred as gross weight.

**Asphalt.** Highly viscous binder occurring as a liquid or semi-solid form of petroleum, also referred as bitumen. May be found in natural deposits or may be a refined product.

**Asphalt concrete.** A graded mixture of aggregate, and filler with asphalt or bitumen, placed hot or cold, and rolled, also referred as asphaltic concrete or bitumen concrete.

**Base course (or base).** The layer or layers of specified or selected material of designed thickness placed on a sub- base or subgrade to support a surface course.

**Bearing strength.** The measure of the ability of a pavement to sustain the applied load, also referred as bearing capacity or pavement strength.

**California Bearing Ratio (CBR).** The bearing ratio of soil determined by comparing the penetration load of the soil to that of a standard material. The method covers evaluation of the relative quality of subgrade soils but is applicable to sub-base and some base course materials.

**Composite pavement.** A pavement consisting of both flexible and rigid layers with or without separating granular layers.

**Flexible pavement.** A pavement structure that maintains intimate contact with and distributes loads to the subgrade and depends on aggregate interlock, particle friction, and cohesion for stability

**Lateral wander.** The path of a given aircraft will deviate relative to the path centred on the longitudinal axis of the pavement in question in a statistically predictable pattern. This phenomenon is referred to as lateral wander.

**Mean aerodynamic chord (MAC).** The MAC is a two-dimensional representation of the whole wing. The pressure distribution over the entire wing can be reduced to a single lift force on and a moment around the aerodynamic centre of the MAC. Centre of gravity position is expressed as percentage of MAC.

**Modulus of elasticity (E).** The modulus of elasticity of a material is a measure of its stiffness. It is equal to the stress applied to it divided by the resulting elastic strain

**Overlay.** An additional surface course placed on existing pavement either with or without intermediate base or sub-base courses, usually to strengthen the pavement or restore the profile of the surface.

**pavement classification number (PCN).** A number expressing the bearing strength of a pavement.

**Pavement classification rating (PCR).** A number expressing the bearing strength of a pavement for unrestricted operations.

**Pavement structure (or pavement).** The combination of sub-base, base course, and surface course placed on a subgrade to support the traffic load and distribute it to the subgrade.

**Poisson's ratio.** The ratio of transverse to longitudinal strains of a loaded specimen.

**Portland cement concrete (PCC).** A mixture of graded aggregate with Portland cement and water.

**Rigid pavement.** A pavement structure that distributes loads to the subgrade having as its surface course a Portland cement concrete slab of relatively high bending resistance, also referred as concrete pavement.

**Sub-base course.** The layer or layers of specified selected material of designed thickness placed on a subgrade to support a base course.

**Subgrade.** The upper part of the soil, natural or constructed, which supports the loads transmitted by the pavement, also referred as the formation foundation.

**Surface course.** The top course of a pavement structure, also referred as wearing course.

## Abbreviations and Acronyms

2D	Dual tandem
ACN	Aircraft classification number
ACR	Aircraft classification rating
AIP	Aeronautical information publication
ASTM	American Society for Testing and Materials
CBR	California bearing ratio
CDF	Cumulative damage factor
CG	Centre of gravity
cm	Centimetre
D	Dual
DSWL	Derived single wheel load
FAA	Federal Aviation Administration
FOD	Foreign object debris
FWD	Falling weight deflectometers
GPR	Ground penetrating radar
HFWD	Heavy falling weight deflectometer
HWD	Heavy weight deflectometer
kN	Kilonewton
LRFD	Load and resistance factor design
MPa	Megapascal
MRGM	Maximum ramp gross mass
NDT	Non-destructive testing
PCA	Portland Cement Association
PCC	Portland cement concrete
PCN	Pavement classification number
PCR	Pavement classification rating
PMP	Pavement management programme
RESA	Runway end safety area
S	Distance between centres of contact areas of dual wheels
SD	Distance between centres of contact areas of diagonal wheels
ST	Distance between axes of tandem wheels
SARP	Standard and Recommended Practice
STAC	Service technique de l'Aviation civile
TSD	Traffic speed deflectometer

Chapter 1

PROCEDURES FOR REPORTING AERODROME PAVEMENT STRENGTH

1.1 Procedures for Pavements Meant for Heavy Aircraft (Aircraft Classification Rating —Pavement Classification Rating (ACR-PCR) Method)

1.1.1 JCAR part 14 *Aerodrome Design and Operations*, specifies that the bearing strength of a pavement intended for aircraft of a mass greater than 5 700 kg should be made available using the aircraft classification rating — pavement classification rating (ACR-PCR) method. To facilitate the proper understanding and usage of the ACR-PCR method, the following explanatory material is provided:

- a) the concept of the method;
- b) how the aircraft classification ratings (ACRs) of an aircraft are determined; and
- c) how the pavement classification ratings (PCRs) of a pavement can be determined using the cumulative damage factor (CDF) concept.

The key parameters of the determination of the pavement classification rating (PCR) are summarized in Figure

1-1

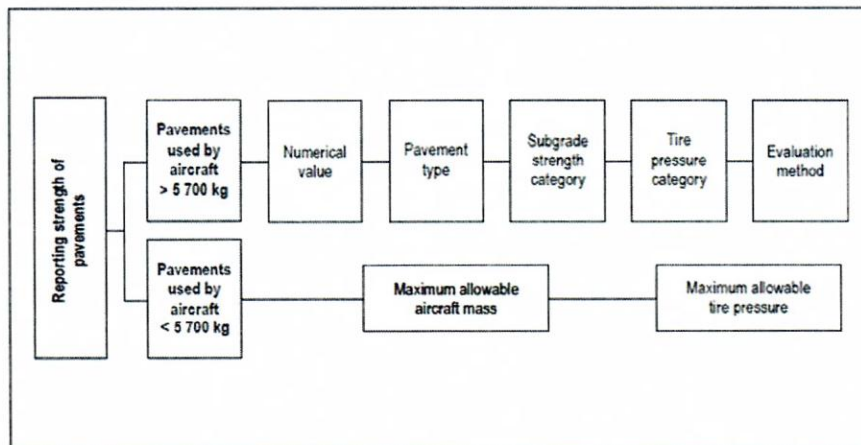

Figure 1-1. Determination of the PCR

### 1.1.2 Concept of the ACR-PCR method

1.1.2. 1 The ACR-PCR method is meant only for the publication of pavement strength data in aeronautical information publications (AIPs). It is not intended for the design or evaluation of pavements, nor does it contemplate the use of a specific method by the aerodrome operator for either the design or evaluation of pavements. In fact, the ACR- PCR method does permit CARC to use any design/evaluation method of their choice. To this end, the method shifts the emphasis from the evaluation of pavements to the evaluation of the load rating of aircraft (ACR) and includes a standard procedure for the evaluation of the load rating of aircraft. The strength of a pavement is reported under the method in terms of the load rating of the aircraft, for example, that which the pavement can accept on an unrestricted basis. When referring to unrestricted operations, it does not mean unlimited operations, but refers to the relationship of the PCR to the aircraft ACR and it is permissible for an aircraft to operate without weight restrictions (subject to tire pressure limitations) when the PCR is greater than or equal to the ACR. The term unlimited operations does not take into account pavement life. The PCR to be reported is such that the pavement strength is sufficient for the current and future traffic analysed and should be re-evaluated if traffic changes significantly. A significant change in traffic would be indicated by the introduction of a new aircraft type or an increase in current aircraft traffic levels not accounted for in the original PCR analysis. CARC can use any method of its choice to determine the load rating of its pavement, provided it uses the CDF concept. The PCR so reported would indicate that an aircraft with an ACR equal to or less than that load rating figure can operate on the pavement, subject to any limitation on the tire pressure.

1.1.2. 2 The ACR-PCR method facilitates the reporting of pavement strengths on a continuous scale. The lower end of the scale is zero and there is no upper end. Additionally, the same scale is used to measure the load ratings of both aircraft and pavements.

1.1.2. 3 To facilitate the use of the method, aircraft manufacturers will publish, in the documents detailing the characteristics of their aircraft, ACRs computed at two different masses (the maximum apron mass and a representative operating mass empty) both on rigid and flexible pavements, and for the four standard subgrade strength categories. The ICAO-ACR computer programme, which is available to all stakeholders, provides any aircraft ACRs at any mass and centre of gravity (CG) position for both flexible and rigid pavement and for the four standard subgrade strength categories. It is to be noted that the mass used in the ACR calculation is a “static” mass and that no allowance is made for an increase in loading through dynamic effects.

1.1.2. 4 The ACR-PCR method also envisages the reporting of the following information in respect of each pavement:

- a) pavement type;
- b) subgrade category;
- c) maximum allowable tire pressure; and
- d) pavement evaluation method used

The data obtained from the characteristics listed above are primarily intended to enable aircraft operators to determine the permissible aircraft types and operating masses, and the aircraft manufacturers to ensure compatibility between airport pavements and aircraft under development. There is, however, no need to report the actual subgrade strength or the maximum allowable tire pressure. Consequently, the subgrade strengths and tire pressures normally encountered have been grouped into categories as indicated in 1.1.3.2. It is sufficient for the airport authority to identify the categories appropriate to its pavement (see also the examples included in JCAR PART 14 ,2.6).

1.1.2. 5In some cases, culverts, bridges, and other surface and subsurface structures can be the critical or limiting element necessitating the reporting of a lower PCR for the pavement. Considerations that permit the use of the ACR- PCR method to limit pavement overloading are not necessarily adequate to protect these structures. Evaluation of, and consideration for, these structures are covered in Chapter 7.

### 1.1.3 How ACRs are determined

1.1.3. 1 ACRs of aircraft are computed under the ACR-PCR method as shown in Figure 1-2.

Relevant documents and software include the:

1. Aircraft characteristics for airport planning (published by the aircraft manufacturers).
2. ICAO-ACR computer programme (current version).

1.1.3. 2 The following are standard values used in the method and include descriptions of the various terms:

#### *Subgrade category*

1.1.3.2.1In the ACR-PCR method, four standard subgrade values (modulus values) are used, rather than a continuous scale of subgrade moduli. The grouping of subgrades with a standard value at the mid-range of each group is considered to be entirely adequate for reporting. Subgrade categories apply to both flexible and rigid pavements.

1.1.3.2.2 The subgrade categories are identified as high, medium, low and ultra-low and are assigned the following numerical values:

**Code A** — High strength; characterized by  $E = 200$  MPa and representing all  $E$  values equal to or above 150 MPa, for rigid and flexible pavements.

**Code B** — Medium strength; characterized by  $E = 120$  MPa and representing a range in  $E$  equal to or above 100 MPa and strictly less than 150 MPa, for rigid and flexible pavements.

**Code C** — Low strength; characterized by  $E = 80$  MPa and representing a range in  $E$  equal to or above 60 MPa and strictly less than 100 MPa, for rigid and flexible pavements.

**Code D** — Ultra-low strength; characterized by  $E = 50$  MPa and representing all  $E$  values strictly less than 60 MPa, for rigid and flexible pavements.

**Concrete working stress for rigid pavements**

1.1.3.2.3 For rigid pavements, a standard stress for reporting purposes is stipulated ( $\sigma = 2.75$  MPa) only as a means of ensuring uniform reporting. The working stress to be used for the design and/or evaluation of the pavements has no relationship to the standard stress for reporting.

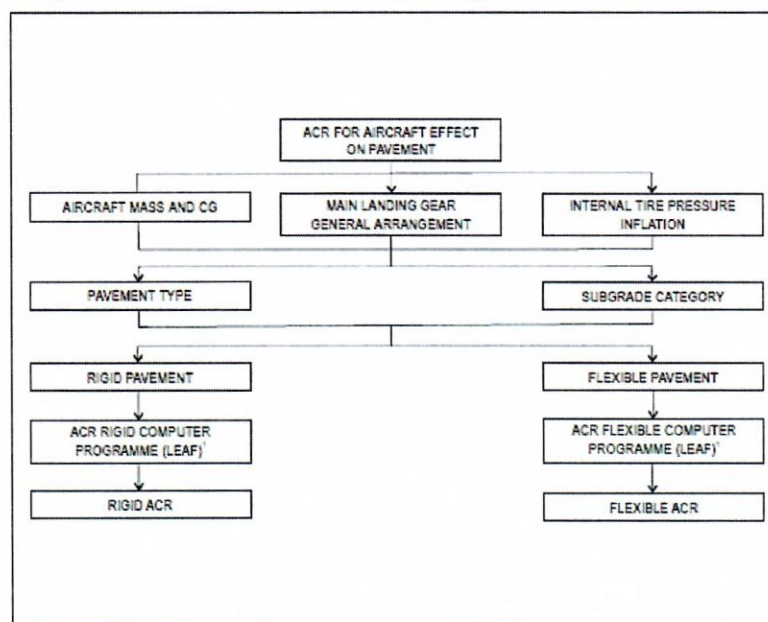

Figure 1-2 ACR Computation<sup>1</sup>

*Mathematically derived single wheel load*

1.1.3.2.4 The concept of a mathematically derived single wheel load has been employed in the ACR-PCR method as a means to define the aircraft landing gear-pavement interaction, without specifying pavement thickness as an ACR parameter. This is done by equating the thickness given by the mathematical model for an aircraft landing gear to the thickness for a single wheel at a standard tire pressure of 1.50 MPa. The single wheel load so obtained is then used without further reference to thickness; this is because the essential significance is attached to the fact of having equal thicknesses, implying “same applied stress to the pavement”, rather than the magnitude of the thickness. The foregoing is in accordance with the objective of the ACR-PCR method for evaluating the relative loading effect of an aircraft on a pavement

*Aircraft classification rating (ACR)*

1.1.3.2.5 The ACR of an aircraft is numerically defined as two times the derived single wheel load, where the derived single wheel load is expressed in hundreds of kilograms. As noted previously, single wheel tire pressure is standardized at 1.50 MPa. Additionally, the derived single wheel load is a function of the subgrade modulus. The aircraft classification rating (ACR) is defined only for the four standard subgrade categories (i.e. high, medium, low and ultra- low). The factor of two in the preceding numerical definition of ACR is used to achieve a suitable ACR versus gross mass scale, so that whole number values of ACR may be used with reasonable accuracy.

1.1.3.2.6 Because an aircraft operates at various mass and CG conditions, the following conventions have been used in ACR computations (see Figures 1-3 and 1-4):

- a) the maximum ACR of an aircraft is calculated at the mass and CG that produces the highest main gear loading on the pavement (i.e. usually the maximum ramp mass and corresponding aft CG. The aircraft tires are considered as inflated to the tire manufacturer’s recommendation for the condition;
- b) relative aircraft ACR charts and tables show the ACR as a function of aircraft gross mass with the aircraft CG as a constant value corresponding to the maximum ACR value (i.e. usually the aft CG for maximum ramp mass) and at the maximum ramp mass tire pressure; and
- c) specific condition ACR values are those ACR values that are adjusted for the effects of tire pressure and/or CG location at a specified gross mass for the aircraft.

*Mathematical models*

1.1.3.3 The sole mathematical model used in the ACR-PCR method is the layered elastic analysis (LEA). The LEA model assumes that several homogeneous, elastic, isotropic layers arranged as a stack, whether flexible or rigid, can represent the pavement structure. Each layer in the system is characterized by an elastic modulus  $E_i$ , Poisson's ratio  $\nu_i$ , and a uniform layer thickness  $t_i$ . Layers are assumed to be of infinite horizontal extent and the bottom or subgrade layer is assumed to extend vertically to infinity (i.e. the subgrade is modelled as an elastic half-space). Due to the linear elastic nature of the model, individual wheel loads can be summed to obtain the combined stress and strain responses for a complex, multiple-wheel aircraft gear load. The use of the LEA model permits the maximum correlation to worldwide pavement design methods.

*Computer programmes*

1.1.3.4 The computer programme was developed using the above LEA mathematical model by the United States Federal Aviation Administration (FAA), named LEAF. LEAF is an open-source computer programme whose source code is available from the FAA, Airport Technology Research and Development Branch, William J. Hughes Technical Center, United States. In addition, a second LEA programme, Alizé-Aeronautique, was developed by the French Institute of Science and Technology for Transport, Development and Networks (IFSTTAR) in partnership with AIRBUS SAS, and has been found to give nearly identical results for equal inputs. The ICAO-ACR computer programme incorporates the LEAF programme and was developed to implement the ACR computational procedures for rigid and flexible pavements. ICAO-ACR is distributed in compiled form as a Visual Basic.NET dynamic-link library (DLL), and may be linked to other programmes that either compute ACR directly or that use the ACR computation to evaluate PCR. By default, the ICAO-ACR programme takes as inputs: the maximum ramp mass for ACR calculations; per cent of maximum ramp mass acting on the main gear (equivalent for this purpose to the aft CG corresponding to maximum ramp mass); the number of wheels; the geometric coordinates of all wheels; and the type of pavement (rigid or flexible). The output is the ACR at each subgrade category and the pavement reference thickness,  $t$ , corresponding to ACR at each subgrade category. Appendix 2 of this Guidance material contains information on linking to the ICAO-ACR library.

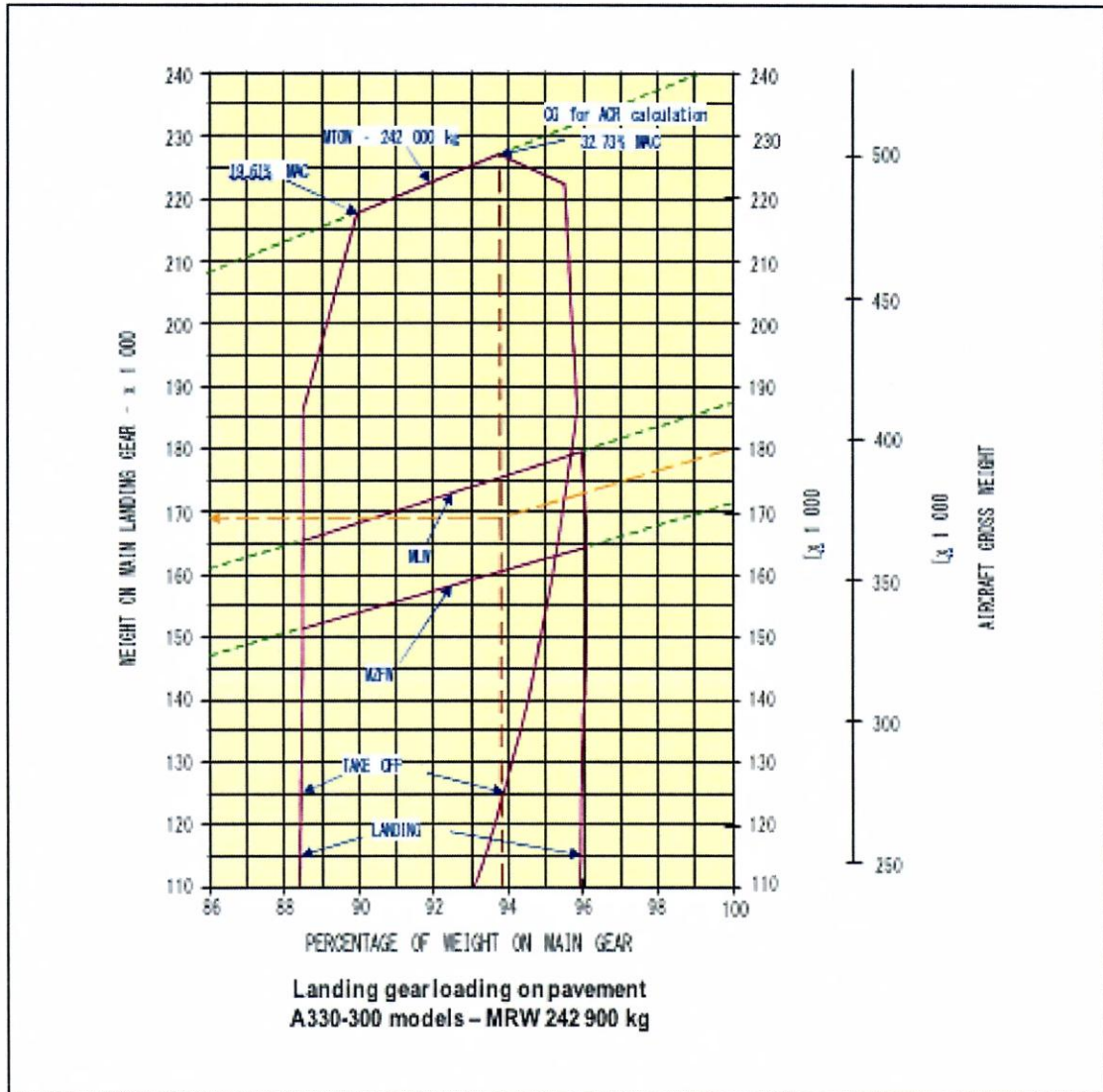

Figure 1-3. Landing gear loading on pavement – Airbus A330-300

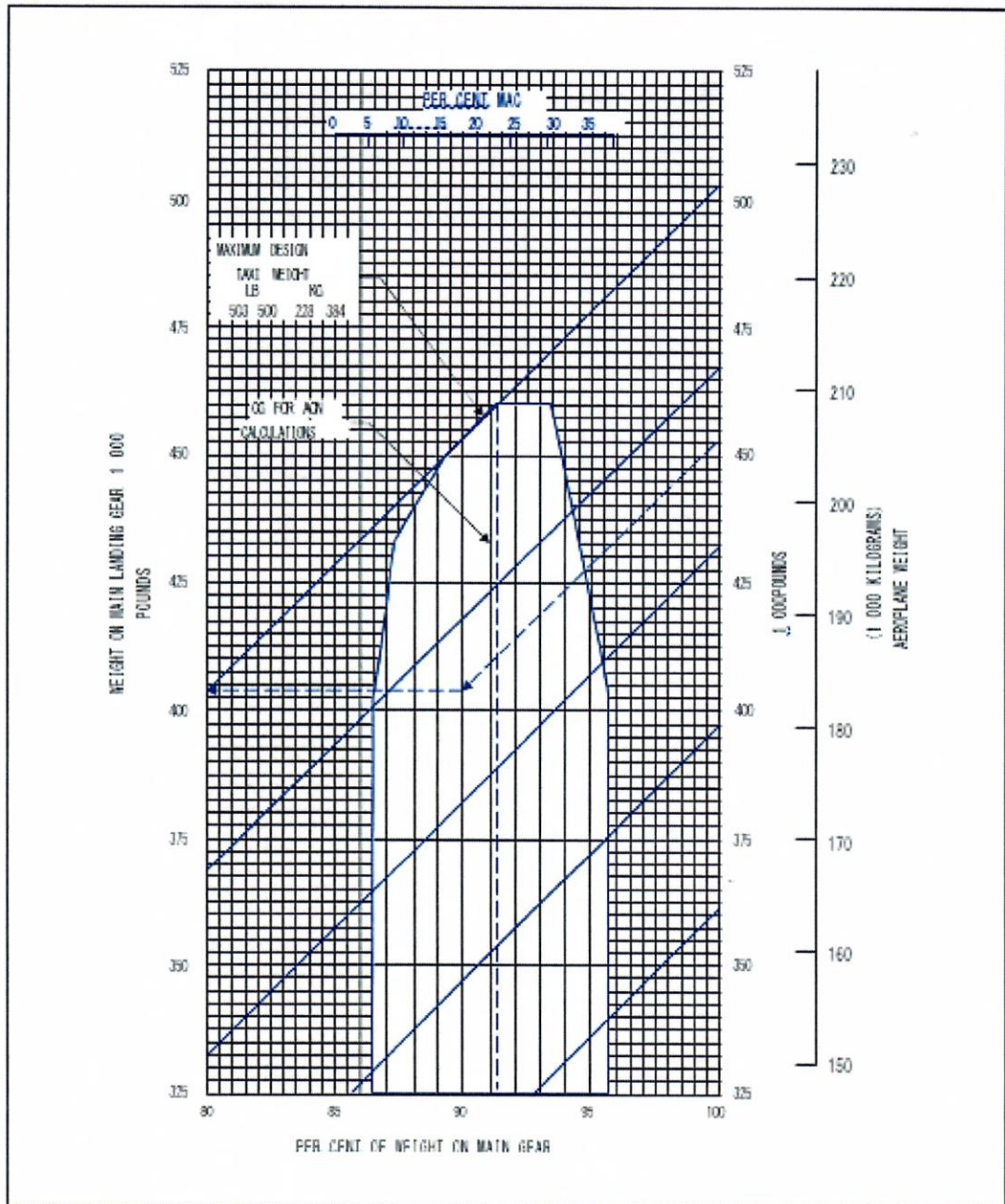

Figure 1-4. Landing gear loading on pavement – Boeing 787-8

*Graphical procedures*

1.1.3.5 Graphical procedures should not be used for determining the ACR. Instead, use the computer programmes as described above.

*Rigid pavements*

1.1.3.6 The rigid pavement ACR procedure relates the derived single wheel load at a constant tire pressure of 1.50 MPa to a reference concrete slab thickness,  $t$ . It takes into account the four subgrade categories detailed in 1.1.3.2.2, and a standard concrete stress of 2.75 MPa. Note that, because a standard concrete stress is used, no information concerning either pavement flexural strength or number of coverages is needed for the rigid ACR computation. The steps below are used to determine the rigid ACR of an aircraft.

*Reference pavement structure*

1.1.3.6.1 Using the aircraft data published by the manufacturer, obtain the reference thickness,  $t$ , for the given aircraft mass, E-value of the subgrade, and standard concrete stress for reporting, i.e. 2.75 MPa. For all four subgrade categories, assume the following cross-section for the LEA model (see Table 1-1):

Table 1-1 reference pavement structure for rigid ACR

Layer description	designation	Thickness, mm	E, MPa	$\nu$
Surface course (PCC)	Layer 1	variable	27 579	0.15
Base course (crushed aggregate)	Layer 2	200	500	0.35
Subgrade	Layer 3	infinite	See 1.1.3.2.2	0.40

The minimum allowable thickness of Layer 1 in the LEA model is 50.8 mm. LEA computations further assume that the horizontal interface between Layer 1 and Layer 2 is not bonded (full slip), and that the horizontal interface between Layer 2 and Layer 3 is full bond. Within the LEA model, stress  $\sigma$  is the maximum horizontal stress computed on the bottom of Layer 1 (the Portland cement concrete layer).

*Evaluation gear*

1.1.3.6.2 ACR value is computed for a single truck in the main landing gear assembly (i.e. for two wheels in a dual, or D assembly, four wheels in a dual-tandem, or 2D assembly, etc.). For more complex landing gear types



with more than two trucks (i.e. having a designation in FAA Order 5300.7, “Standard Naming Convention for Aircraft Landing Gear Configurations” consisting of more than two characters), the individual truck in the main gear assembly with the largest rigid ACR determines the rigid ACR for the aircraft. All trucks are evaluated at the mass and CG that produce the highest total main gear loading on the pavement.

#### *Stress evaluation points*

1.1.3.6.3 The number of LEA evaluation points is equal to the number of wheels in the evaluation gear. The evaluation points are located at the bottom of Layer 1, below the centre point of each wheel. The thickness,  $t$ , of Layer 1 is adjusted until the maximum stress evaluated over all evaluation points is equal to 2.75 MPa. The resulting  $t$  is the reference thickness for the ACR.

#### *Derived single wheel load (DSWL) calculation*

1.1.3.6.4 Using the above reference thickness and the same LEA model as in 1.1.3.6.1 obtain a derived single wheel load for the selected subgrade. Maintaining the constant tire pressure of 1.50 MPa, the single wheel load magnitude is adjusted until the maximum horizontal stress at the bottom of Layer 1 is equal to 2.75 MPa. For evaluation of stresses under the single wheel load, use one evaluation point located at the bottom of Layer 1, directly below the centre of the wheel.

#### *Modified DSWL calculation for lightweight aircraft*

1.1.3.6.5 For some lightweight aircraft, the required reference thickness,  $t$ , is less than the minimum allowable thickness. Use the following modified steps to compute DSWL only when the theoretical thickness of Layer 1 that makes the maximum stress equal to 2.75 MPa is less than 50.8 mm:

- a) determine the value of stress (less than 2.75 MPa) corresponding to the minimum allowable concrete thickness (50.8 mm); and
- b) calculate DSWL for the selected subgrade using the minimum thickness of the reference structure. Maintaining the constant tire pressure of 1.50 MPa, the single wheel load magnitude is adjusted until the maximum horizontal stress at the bottom of Layer 1 is equal to the value determined in a) above.

*ACR calculation*

1.1.3.6.6 The aircraft classification rating, at the selected mass and subgrade category, is two times the derived single wheel load in hundreds of kilograms. The numerical value of ACR may be rounded to the nearest multiple of ten for reporting.

*Flexible pavements*

1.1.3.7 The flexible pavement ACR procedure relates the derived single wheel load at a constant tire pressure of 1.50 MPa to a reference total thickness,  $t$ , computed for 36 500 passes of the aircraft. It takes into account the four subgrade categories detailed in 1.1.3.2.2.

*Reference pavement structures*

1.1.3.8 The ACR-PCR system must cover a wide range of aircraft, weighing from a few to several hundreds of tons. Reference structures have been chosen to produce appropriate thicknesses for the standard subgrade categories for the range of aircraft weights used. Determining the reference structures for the flexible ACR computation consists of defining the materials and constitutive properties of the several layers. All layers are defined by: Elastic modulus  $E$ , Poisson's ratio  $\nu$ , and (except for the design layer) the thickness  $t$ . LEA computations assume that all horizontal interfaces between layers are fully bonded. Tables 1-2 and 1-3 define the reference structures to be used in calculating flexible ACR.

Table 1-2. Reference structure for flexible ACR (aircraft fitted with two or fewer wheels on all legs of the main landing gear)

Layer description	Thickness , mm	E, MPa	$\nu$
Surface course (asphalt)	76	1 379	0.35
Base course (crushed aggregate)	Variable	See 1.1.3.10	0.35
Subgrade	Infinite	See 1.1.3.2.2	0.35

Table 1-3. Reference structure for flexible ACR (aircraft fitted with more than two wheels on any leg of the main landing gear)

Layer description	Thickness , mm	E, MPa	$\nu$
Surface course (asphalt)	127	1 379	0.35
Base course (crushed aggregate)	Variable	See 1.1.3.10	0.35
Subgrade	Infinite	See 1.1.3.2.2	0.35



1.1.3.9 In the LEA model, the minimum allowable thickness of the variable (base course) layer is 25.4 mm. Because of the intentionally limited number of reference structures, computed layer thicknesses may not be realistic at the extremes of the aircraft weight range. However, this does not invalidate the ACR concept, in which  $t$  is a relative indicator rather than the basis for a practical design.

#### *Base layer modulus*

1.1.3.10 All flexible reference pavement structures include a variable thickness layer above the subgrade, representing a crushed aggregate base layer. The modulus of the variable thickness layer is not fixed in the ACR procedure, but is a function of the thickness and of the subgrade modulus. Within the LEA model, the base layer is subdivided into smaller sublayers and a modulus value is then assigned to each sublayer using a recursive procedure as explained below. Modulus values are assigned to the sublayers following the procedure in the FAA computer programme FAARFIELD (version 1.42), for item P-209 (crushed aggregate). The steps in the procedure are as follows:

#### **Step 1**

Determine the number of sublayers  $N$ . If the base layer thickness  $t_B$  is less than 381 mm, then  $N = 1$  and sublayering is not required. If  $t_B$  is greater than or equal to 381 mm, the number of sublayers is:

$$N = \text{int} \left( \frac{t_B}{254} + 0.5 \right)$$

where  $t_B$  is in mm, and the integer function returns the integer part of the argument (i.e. rounds down to the next whole number).

#### **Step 2**

Determine the thickness of each sublayer. If  $N = 1$ , then the sublayer thickness is equal to the base layer thickness  $t_B$ . If  $N > 1$ , then the thickness of the bottom  $N - 1$  sublayer is 254 mm, and the thickness of the top sublayer is  $t_B - (N - 1) \times 254$  mm. Note that, in general, the  $N$  sub-layers do not have equal thickness. For example, if

the thickness of the base layer is 660 mm, then from Step 1, the number of sublayers is three. The bottom two sublayers are each 254 mm, while the top sublayer is  $660 - 2 \times 254 = 152$  mm.

### Step 3

Assign a modulus value  $E$  to each sublayer. Modulus values increase from bottom to top, reflecting the effect of increasing confinement of the aggregate material. Modulus values are given by the following equation:

$$E_n = E_{n-1} \times \{1 + [\log_{10}(t_n) - \log_{10}(25.4)] \times (c - d[\log_{10}(E_{n-1}) + \log_{10}(145.037)])\}$$

Where:

$E_n$  = the modulus of the current sublayer in MPa;

$E_{n-1}$  = the modulus of the sublayer immediately below the current sublayer; or the modulus of the subgrade layer when the current sublayer is the bottom sublayer;

$t_n$  = the thickness of the current sublayer in mm;

$c = 10.52$  (constant); and

$d = 2.0$  (constant).

The above equation is applied recursively beginning with the bottom sublayer

### Step 4

The modulus assignment procedure in Step 3 must be modified for the top two sublayers whenever  $t_B$  is between 127 mm and 254 mm greater than an integer multiple of 254 mm. This modification ensures that the modulus of all sublayers is a continuous function of the layer thickness, with no gaps. If  $N > 1$  and  $t_B$  exceeds an integer multiple of 254 mm by more than 127 mm, but less than 254 mm, then:

- The top sub-layer (sub-layer  $N$ ) is between 127 mm and 254 mm thick, and all sublayers below it (sublayers 1 to  $N-1$ ) are 254 mm thick.
- Using the equation in Step 3, compute the modulus  $E_{254}$  that would be obtained for sublayer  $N$  for an assumed top sublayer thickness  $t_n$  equal to 254 mm.
- Compute the modulus of sublayer  $N-1$  (i.e. the sublayer immediately below the top sub-layer) using the equation in Step 3, but substituting  $t_n = 508 \text{ mm} - t_N$ , where  $t_N$  is the actual thickness of the top sublayer in mm.

- d) Compute the modulus of sublayer  $N$  by linear interpolation between  $E_{N-1}$  (the modulus of sublayer  $N-1$ ) and  $E_{254}$

*Evaluation gear*

$$E_N = E_{N-1} + t_N \times \frac{E_{254} - E_{N-1}}{254}$$

1.1.3.11 The ACR value is computed using all wheels in the main landing gear (wheels in the nose landing gear are not included). Main landing gears are evaluated at the mass and CG that produces the highest total main gear loading on the pavement.

*Strain evaluation points*

1.1.3.12 Within the LEA model, strain  $\epsilon$  is the maximum vertical strain computed on the top surface of the subgrade (lowest) layer. In the ICAO-ACR computer programme, strains are computed at specific evaluation points based on the geometry of the evaluation gear. Evaluation points are placed directly below the centre point of each wheel, and at the points defined by a regular rectangular grid spaced at 10-cm intervals, and oriented parallel to the principal axes of the gear.

1.1.3.12.1 For simple main landing gears consisting of two trucks (i.e. for two wheels in a dual, or D assembly, four wheels in a dual-tandem, or 2D assembly, etc.), the grid origin is set at the geometric centre of one truck. The limits of the grid extend 30 cm beyond the maximum wheel coordinates on all sides of the truck (Figure 1-5).

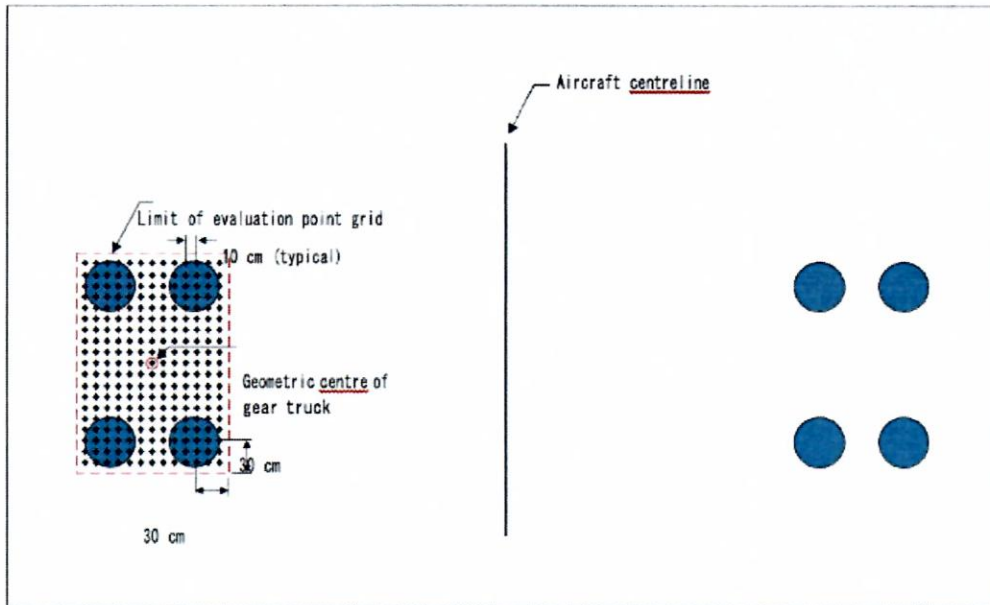

Figure 1-5. Grid definition for simple main landing gear arrangement

1.1.3.12.2 For more complex gear types with more than two trucks comprising the main landing gear assembly (i.e. all aircraft whose gear designation consists of more than two characters in FAA Order 5300.7, “Standard Naming Convention for Aircraft Landing Gear Configurations”), the origin of the grid is at the geometric centre of the entire landing gear assembly. The limits of the grid extend 30 cm beyond the maximum wheel coordinates on all sides (see Figure 1-6). For the purpose of computing the geometric centre coordinates, all included wheels should be weighted equally, regardless of different wheel loads or tire pressures.

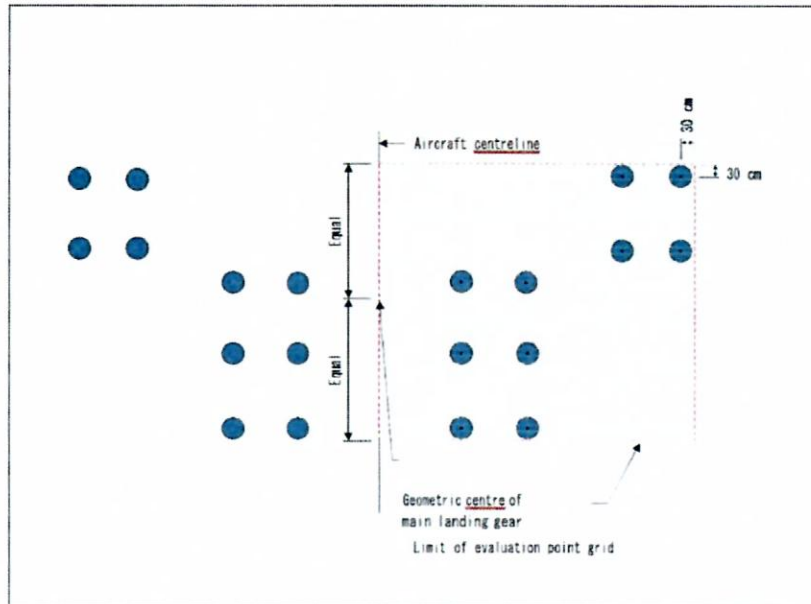

Figure 1-6. Grid definition for complex aircraft main landing gear

1.1.3.12.3 Strain  $\epsilon$  is the maximum of the strains computed for all evaluation points

*Note: ICAO-ACR automatically detects symmetries within the evaluation point grid to reduce the number of required computations. In the case of the B787-9, only one half of the evaluation point grid may actually be computed due to the transverse symmetry.*

*Damage model*

1.1.3.13 The flexible ACR procedure relies on the subgrade failure criterion associated with the elementary damage law:

$$D_e(\epsilon) = \frac{1}{C_e(\epsilon)}$$

This elementary damage law is based on the notion of loading cycle (single-peak strain profile with maximum value  $\epsilon$ ), which cannot be applied to arrangements with axles in tandem producing complex strain profiles, possibly with multiple strain peaks and no return to zero-strain between peaks. Therefore, the elementary damage law is extended to a continuous integral form:



$$D = \int_{x=-\infty}^{x=+\infty} \left\langle \frac{dD_e(x)}{dx} \right\rangle dx$$

where  $x$  refers to the longitudinal position along the landing gear and  $\langle y \rangle$  to the positive part of  $y$ . Details of the integral formulation are described in Appendix 3.

#### DSWL calculation

1.1.3.14 Using the pavement requirement data published by the manufacturer, calculate the reference thickness,  $t$ , for the given aircraft mass, E-value of the subgrade, and 36 500 passes of the aircraft. Use the appropriate reference pavement structure from 1.1.3.8 with evaluation points as described in 1.1.3.12. The thickness of the variable (design) layer is adjusted until the damage as computed from 1.1.3.13 is equal to 1.0. The resulting thickness,  $t$ , is the reference thickness for ACR.

1.1.3.15 Using the above reference thickness and the same LEA model as in 1.1.3.13, obtain a derived single wheel load for the selected subgrade. Maintaining the constant tire pressure of 1.50 MPa, the single wheel load magnitude is adjusted until the damage is equal to 1.0 for 36 500 passes. For evaluation of strains under the single wheel load, use one evaluation point located at the top of the subgrade, directly below the centre of the wheel.

#### *Modified DSWL calculation for lightweight aircraft*

1.1.3.16 For some lightweight aircraft, the required reference thickness,  $t$ , is less than the minimum allowable thickness. Use the following modified steps to compute DSWL only when the theoretical thickness of the variable design layer that makes the damage equal to 1.0 for 36 500 aircraft passes is less than 25.4 mm:

- a) determine the value of maximum vertical strain at the top of the subgrade corresponding to the minimum allowable variable design layer thickness (25.4 mm); and
- b) calculate DSWL for the selected subgrade using the minimum thickness of the reference structure. Maintaining the constant tire pressure of 1.50 MPa, the single wheel load magnitude is adjusted until the maximum vertical strain at the top of the subgrade is equal to the value determined in a) above.

#### *ACR calculation*

1.1.3.17 The aircraft classification rating, at the selected mass and subgrade category is two

times the derived single wheel load in hundreds of kilograms. The numerical value of ACR may be rounded to the nearest multiple of ten for reporting.

#### *Tire pressure adjustment to ACR*

1.1.3. 18 Aircraft normally have their tires inflated to the pressure corresponding to the maximum gross mass without engine thrust, and maintain this pressure regardless of the variation in take-off masses. There are times, however, when operations at reduced masses, modified CG and/or reduced tire pressures are productive and reduced ACRs need to be calculated. To calculate the ACR for these conditions, the adjusted tire inflation pressure should be entered in the ICAO-ACR dedicated input field.

1.1.3. 19 Examples of these calculations are as follows:

Example 1: Find the ACR of a B747-400 at 397 800 kg on a rigid pavement, resting on a medium-strength subgrade. The tire pressure of the main wheels is 1.38 MPa. From the manufacturer's data, it is known that, at the aft CG for maximum ramp mass, 93.33 per cent of the aircraft mass is on the main gear.

Solution: The ACR is found based on steps as described in 1.1.3.6. These steps are automatically implemented in the ICAO-ACR programme referenced in 1.1.3.4.

**Step 1.** Use the main gear characteristics and the standard rigid pavement structure to determine the reference ACR thickness  $t$ . Compute ACR for one four-wheel truck of the 16-wheel B747-400 main gear. All trucks in the B747-400 main gear have the same load, tire pressure and wheel configuration; therefore, the selection of the single truck to be used for evaluation is arbitrary. The LEAF programme described in 1.1.3.4 was used to determine stresses at evaluation points at the bottom of the concrete layer under each of the four wheels in one truck. The LEAF input data for the B747-400 aircraft are shown in Figure 1-7. In Figure 1-7, the force acting on the single truck, 910.22 kN, is the gross weight of the aircraft times 93.33 per cent, divided by four. From this analysis, for the given load and gear geometry, a concrete thickness of 381 mm produces a maximum horizontal concrete stress of 2.75 MPa. Due to symmetry, the maximum horizontal stress under all four wheels is the same. Therefore, the reference thickness,  $t$ , is 381 mm.

**Step 2.** Determine the derived single wheel load corresponding to the reference ACR thickness  $t$ . Use the same layered elastic structure as in Step 1 with Layer 1 thickness equal to 381 mm. Apply a single wheel load

with constant tire pressure  $P_s$  equal to 1.50 MPa. Vary the magnitude of the derived single wheel load until the horizontal stress computed at a single evaluation point located at the bottom of the concrete layer is 2.75 MPa. Figure 1-8 shows the LEAF programme output for this case. From Figure 1-8, the tire load producing the standard stress  $\sigma = 2.75$  MPa at the standard tire pressure = 1.50 MPa is 336.17 kN, corresponding to a single wheel load of 34 280 kg.

**Step 3.** The numerical value of ACR is two times the single wheel load in kg determined in Step 2, divided by 100. Therefore, the ACR on medium-strength (“B”) subgrade is  $2 \times 343 = 686$ . The ACR on subgrade category “B” will be reported as 690

Layer No.	Thickness, mm	Elasticity Modulus, MPa	Poisson's Ratio	Interface Condition		
1	381.00	27,579.03	0.1500	0.0000		
2	200.00	500.00	0.3500	1.0000		
3	0.00	120.00	0.4000	1.0000		
Aircraft No. 1 B-747-Wing : Aircraft design load : Not Applicable Fraction of load on main gear : 100.0 Gear load, KN : 910.22 Number of tires : 4						
Tire No.	Radius (mm)	Cont.Area (sq.mm)	Cont.Press (MPa)	Tire Load (kiloNewtons)	X-Coord (mm)	Y-Coord (mm)
1	229	165,021	1.38	227.56	-559	0
2	229	165,021	1.38	227.56	-559	0
3	229	165,021	1.38	227.56	-559	1,473
4	229	165,021	1.38	227.56	-559	1,473

Figure 1-7. Input data for B747 – 400 evaluation aircraft in programme LEAF in ACR example 1

Layer No.	Thickness mm	Elasticity Modulus, MPa	Poisson's Ratio	Interface Condition
1	381.00	27,579.03	0.1500	0.0000
2	200.00	500.00	0.3500	1.0000
3	0.00	120.00	0.4000	1.0000

Aircraft No. 1 SWL-ACR :						
Aircraft design load : Not Applicable						
Fraction of load on main gear : 100.0						
Gear load, KN : 336.17						
Number of tires : 1						

Tire No.	Radius (mm)	Cont.Area (sq.mm)	Cont.Press (MPa)	Tire Load (kiloNewtons)	X-Coord (mm)	Y-Coord (mm)
1	287	224,114	1.50	336.17	0	0

Eval point = 1	Layer No. = 1	Z-Depth = 380.9900			
X-Coord. = 0.000	Y-Coord. = 0.000				
VERT STR	HOR Y STR	HOR X STR	XZ SHEAR	YZ SHEAR	XY SHEAR
Stress -5.036809E-002	2.747433E+000	2.747433E+000	0.000000E+000	0.000000E+000	0.000000E+000
Strain -3.171243E-005	8.495126E-005	8.495126E-005	0.000000E+000	0.000000E+000	0.000000E+000
Displ 7.395790E-001	0.000000E+000	0.000000E+000			
PRIN 1	PRIN 2	PRIN 3	MAX SHEAR	OCT NORMAL	OCT SHEAR
Stress 2.747441E+000	2.747425E+000	-5.036809E-002	1.398904E+000	1.814833E+000	1.318896E+000
Strain 8.495158E-005	8.495094E-005	-3.171243E-005			

Figure 1-8 . Data for derived single wheel load in programme LEAF in ACR example 1 (stresses are in MPa)

Example 2: Find the ACR of B787-9 at 254 692 kg on a flexible pavement resting on a low-strength subgrade. The tire pressure of the main wheels is 1.56 MPa. From the manufacturer’s data, it is known that, at the aft CGfor maximum ramp mass, 92.46 per cent of the aircraft mass is on the main gear.

Solution:The ACR is found using the steps as described in 1.1.3.7. These steps are automatically implemented in the ICAO-ACR programme referenced in 1.1.3.4

**Step 1.** Use the main gear characteristics and the standard flexible pavement structure for aircraft with more than two wheels to determine the reference ACR thickness *t*. From FAA Order 5300.7, “Standard Naming Convention for Aircraft Landing Gear Configurations”, the B787-9 has main gear designation 2D. As a simple landing gear (the gear designation does not exceed two characters), the strain evaluation points for ACR are based on a single truck. Use the ICAO-ACR programme to find the reference thickness *t* = 796 mm for 36 500 passes of the evaluated aircraft. The layered elastic structure for subgrade category C (low-strength) with moduli assigned according to 1.1.3.10 is:



Layer	Thickness, mm	E, MPa	$\nu$
Asphalt	127	1 379	0.35
Sublayer 3	161	769.52	0.35
Sublayer 2	254	680.85	0.35
Sublayer 1	254	271.27	0.35
Subgrade	infinite	80	0.35

**Step 2.** Determine the DSWL corresponding to the reference ACR thickness  $t$ . Use the same layered elastic structure as in Step 1. Apply a single wheel load with constant tire pressure  $P_s$  equal to 1.50 MPa. Vary the magnitude of the DSWL until damage is 1.0 for 36 500 passes. From the ICAO-ACR programme, the computed value of the DSWL is 37 522.2 kg, corresponding to a maximum vertical strain on the top of the subgrade of 0.001325. Note that for the single wheel load there is no multi-axle effect, therefore the maximum strain can be found directly by substituting 36 500 passes in the elementary damage law equation in Appendix 3, Section 1.

**Step 3.** The numerical value of ACR is two times the single wheel load in kg determined in Step 3, divided by 100. Therefore, the ACR on low-strength (“C”) subgrade is  $2 \times 375 = 750$ . The ACR on subgrade category “C” will be reported as 750.

Example 3: Find the ACR of A380-800 at 562 000 kg on a flexible pavement resting on a medium-strength subgrade. The tire pressure of the main wheels is 1.50 MPa. From the manufacturer’s data, it is known that, at the aft CG for maximum ramp mass, 95.13 per cent of the aircraft mass is on the main gear (57.08 per cent on the body landing gear and 38.05 per cent on the wing landing gear).

Solution: The ACR is found using the steps as described in 1.1.3.7. These steps are automatically implemented in the ICAO-ACR programme referenced in 1.1.3.4.

**Step 1.** Use the main gear characteristics and the standard flexible pavement structure for aircraft with more than two wheels to determine the reference ACR thickness  $t$ . From FAA Order 5300.7, “Standard Naming Convention for Aircraft Landing Gear Configurations”, the A380-800 has main gear designation 2D/3D2. As a complex landing gear (the gear designation exceeds two characters), the strain evaluation Points for ACR are based on the entire landing gear assembly. Use the ICAO-ACR programme to find the reference thickness  $t = 616$  mm. The layered elastic structure for subgrade category B (medium-strength) with moduli assigned according to 1.1.3.10 is:



<i>Layer</i>	<i>Thickness, mm</i>	<i>E, MPa</i>	<i>ν</i>
Asphalt	127	1379	0.35
Sublayer 2	235	698.75	0.35
Sublayer 1	254	372.29	0.35
Subgrade	infinite	120	0.35

**Step 2.** Determine the DSWL corresponding to the reference ACR thickness  $t$ . Use the same layered elastic structure as in Step 1. Apply a single wheel load with constant tire pressure  $P_s$  equal to 1.50 MPa. Vary the magnitude of the DSWL until  $CDF = 1.0$  for 36 500 passes. From the ICAO-ACR programme, the computed value of the DSWL is 28 902.4 kg, corresponding to a maximum vertical strain on the top of the subgrade of 0.001325. Note that for the single wheel load there is no multi-axle effect, therefore the maximum strain can be found directly by substituting 36 500 passes in the elementary damage law equation in Appendix 3, Section 1.

**Step 3.** The numerical value of the ACR is two times the single wheel load in kg determined in Step 3, divided by 100. Therefore, the ACR on low-strength (“B”) subgrade is  $2 \times 289 = 578$ . The ACR on subgrade category “B” will be reported as 580.

1.1.4 How PCRs are determined

1.1.4.1 This section is intended to provide a model procedure for PCR determination and publication, using the CDF concept.

1.1.4.2 CDF concept.

1.1.4.2.1 The CDF is the amount of the structural fatigue life of a pavement that has been used up. It is expressed as the ratio of applied load repetitions to allowable load repetitions to failure, or, for one aircraft and constant annual departures where a coverage is one application of the maximum strain or stress due to load on a given point in the pavement structure:

$$CDF = \frac{\textit{Applied coverages}}{\textit{Coverages to failure}}$$

*Note 1. When  $CDF = 1$ , the pavement subgrade will have used all of its fatigue life.*



*Note 2. When  $CDF < 1$ , the pavement subgrade will have some remaining life and the value of CDF will give the fraction of the life used.*

*Note 3. When  $CDF > 1$ , all of the fatigue life will have been used and the pavement subgrade will have failed.*

1.1.4.2.2 In these definitions, failure means failure according to the assumptions and definitions on which the design procedures are based. A value of CDF greater than one does not mean that the pavement will no longer support traffic, but that it will have failed according to the definition of failure used in the design procedure. The thickness design is based on the assumption that failure occurs when  $CDF = 1$ .

1.1.4.2.3 Multiple aircraft types are accounted for using Miner's Rule:

$$CDF = CDF_1 + CDF_2 + \dots + CDF_N$$

where  $CDF_i$  is the CDF for each aircraft in the traffic mix and N is the number of aircrafts in the mix.

1.1.4.2.4 Since the PCR relates to the structural pavement life, the CDF is based on the subgrade failure mode.

#### 1.1.4.3 Lateral wander

1.1.4.3.1 The distribution of aircraft passes for a given aircraft type over the life of the pavement is described by a Gaussian (or normal) distribution function, with a standard deviation  $s$  that depends on several factors: the type of aircraft, its ground speed, and the manoeuvring area. Another term that is frequently used is the amplitude of lateral wander, which is twice the standard deviation.

1.1.4.3.2 High-speed sections (e.g. runways) are associated with higher values of  $s$  than moderate-speed sections (e.g. taxiways), while wander may be considered negligible ( $s \cong 0$ ) on low-speed sections (e.g. aprons).

1.1.4.3.3 The following values of standard deviation may be used independently of the type of aircraft:

<i>Pavement section</i>	<i>Standard deviation <math>s</math> (metres)</i>
High-speed sections (runway, rapid exit taxiway)	0.75
Moderate-speed sections (taxiways)	0.5
Aprons and low-speed sections	0

1.1.4.3.4 The FAA design procedure assumes  $s = 0.776$  metres (30.54 inches) independently of the type of aircraft or feature.



1.1.4.3.5 The effect of lateral wander may be considered indirectly by computing a pass-to-coverage (P/C) ratio from the normal aircraft distribution. Alternatively, the distribution function can be discretized (mapped to a calculation grid) and the wandered damage computed numerically. A more closely spaced grid results in higher calculation times but greater accuracy. A grid spacing of 5 cm has been found to give good results. Discretization on a grid with transverse pitch  $\Delta y$  results in the distribution of the paths on  $n_w$  lines  $y_w$  of the grid, which are associated with percentages of the traffic  $P_w$ .

1.1.4.3.6 The effect of including lateral wander is to reduce the theoretical damage that would be caused by having all aircraft traverse a single path, i.e.  $D_{wander} < D_{zero\ wander}$ . Zero wander implies that the number of passes equals the number of coverages ( $P/C = 1$ ).

*Calculation of damage assuming lateral wander*

1.1.4.3.7 When the grid method is used, it is necessary to obtain the total damage (for one aircraft) by summing the individual damage contributions from each of the  $n_w$  profiles. This step consists of adding up the damage profiles  $D_{no\ wander}(y, z)$ , offset by the value  $y_w$  and weighted by probability of occurrence  $P_w$  in the lateral wander law:

$$D_{wander}(y, z) = \sum_{w=1}^{n_w} P_w \times D_{no\ wander}(y - y_w, z)$$

where  $n_w$  = total number of damage profiles.

*Determination of the cumulative damage for a traffic mix*

1.1.4.3.8 The cumulative damage for all aircraft comprising an aircraft mix is given by the following equation, which treats the additive effect of damage according to Miner’s Rule:

$$CDF(y_j, z) = \sum_{i=1}^m N_i \times (D_{wander})_i(y_j, z)$$

where  $m$  = total number of aircraft in the traffic mix;  $i$  = aircraft within the aircraft mix; and  $N_i$  = number of aircraft passes.



1.1.4.3.9 The resulting curve represents the variation of the CDF in the transverse direction (relative to the longitudinal centreline).

1.1.4.3.10 If the P/C ratio is computed for each aircraft  $i$ , an equivalent expression giving CDF at lateral offset  $j$  is:

$$CDF(y_j, z) = \sum_{i=1}^m \frac{N_i}{(P/C)^j} \times D_i(z)$$

where  $D_i$  is the damage contributed by a pass of aircraft  $i$ , including any effects of interaction between wheels in tandem.

#### 1.1.4.4 Pavement strength reporting

1.1.4.4.1 PCR shall be reported using the following codes:

- a) Rigid pavement = R
- b) Flexible pavement = F

*Note. If the actual pavement construction is composite or non-standard, include a note to that effect*  
*Subgrade category*

1.1.4.4.2 The subgrade categories are:

- a) High strength: Characterized by  $E = 200$  MPa, and representing all  $E$  values equal to or above 150 MPa for rigid and flexible pavements = Code A.
- b) Medium strength: Characterized by  $E = 120$  MPa and representing a range in  $E$  equals to or above 100 and strictly less than 150 MPa, for rigid and flexible pavements = Code B.
- c) Low strength: Characterized by  $E = 80$  MPa and representing a range in  $E$  equals to or above 60 and strictly less than 100 MPa, for rigid and flexible pavements = Code C.
- d) Ultra-low strength: Characterized by  $E = 50$  MPa and representing all  $E$  values strictly less than 60 MPa, for rigid and flexible pavements = Code D.

1.1.4.4.3 For existing pavements initially designed with the California bearing ratio (CBR) design procedure, subgrade modulus values can be determined in a number of ways. The procedure that will be applicable in most cases is to use available CBR values and substitute the relationship:

$E = 1\,500 \times \text{CBR}$  ( $E$  in psi) or  $10 \times \text{CBR}$  ( $E$  in MPa)

1.1.4.4.4 This method provides designs compatible with the earlier flexible design procedure based on subgrade CBR, but other accepted equivalencies can also be used (Shell method, Airport Pavement Design System Knowledge Base (APSDS) method, etc.). Subgrade modulus values for PCR determination may also be determined from direct soil testing (e.g. lightweight deflectometer, plate test).

1.1.4.4.5 Similarly, for rigid pavement design, the foundation modulus can be expressed as the modulus of subgrade reaction  $k$  or as the elastic (Young's) modulus  $E$ . However, all structural computations are performed using the elastic modulus  $E$ . If the foundation modulus is input as a  $k$  value it can be converted to the equivalent  $E$  value using the following equations:

$$ESG = 20.15 \times K^{1.284}$$

where ESG = Elastic (Young's) modulus of the subgrade, pounds per square inch (psi); and  $K$  = Modulus of subgrade reaction, pounds per cubic inch (pci).

1.1.4.4.6 For new pavement construction, the subgrade modulus value for PCR determination should be the same value used for pavement thickness design.

1.1.4.4.7 The maximum allowable tire pressure categories are:

- a) Unlimited: no pressure limit = Code W.
- b) High: pressure limited to 1.75 MPa = Code X.
- c) Medium: pressure limited to 1.25 MPa = Code Y.
- d) Low: pressure limited to 0.5 MPa = Code Z.

1.1.4.4.8 There are two types of evaluation methods, mainly:

- a) Technical evaluation: representing a specific study of the pavement characteristics and its capability of supporting the aircraft mix that is intended to serve, using the CDF concept through a mechanistic design/evaluation method calibrated against observed pavement behaviour = Code T.
- b) Using aircraft experience: representing a knowledge of the specific type and mass of aircraft satisfactorily being supported under regular use = Code U.

1.1.4.5 PCR recommended procedure for technical evaluation (T)

1.1.4.5.1 The following recommended PCR procedure reduces to the computation of an aircraft ACR. The steps below can be used to convert the mix of using aircraft traffic to an equivalent critical, or reference aircraft at maximum allowable gross weight, which will then produce a CDF of 1.0 on the evaluated pavement. The ACR calculation follows the ACR procedure described in 1.1.3.

1.1.4.5.2 The PCR procedure considers the actual pavement characteristics at the time of the evaluation — considering the existing pavement structure, and the aircraft traffic forecast to use the pavement over its design structural life (for new pavement construction) or estimated remaining structural life (for in service pavements). The PCR should be valid only for this usage period. In case of major pavement rehabilitation or significant traffic changes compared to the initial traffic, a new evaluation should be performed.

1.1.4.5.3 The PCR procedure involves the following steps:

- 1) collect all relevant pavement data (layer thicknesses, elastic moduli and Poisson's ratio of all layers, using projected aircraft traffic) using the best available sources;
- 2) define the aircraft mix by aircraft type, number of departures (or operations consistent with pavement design practices), and aircraft weight that the evaluated pavement is expected to experience over its design or estimated remaining structural life (according to the manoeuvre area (runway, taxiway, apron, ramp), the traffic can be assigned a lateral wander characterized by a standard deviation as detailed in 1.1.4.2.1);
- 3) compute the ACRs for each aircraft in the aircraft mix at its operating weight and record the maximum ACR aircraft (ACR computations must follow the procedure in 1.1.3);
- 4) compute the maximum CDF of the aircraft mix and record the value (the CDF is computed with any damage/failure model consistent with the procedure used for pavement design);
- 5) select the aircraft with the highest contribution to the maximum CDF as the critical aircraft. This aircraft is designated AC(i), where i is an index value with an initial value 1. Remove all aircraft other than the current critical aircraft AC(i) from the traffic list;
- 6) adjust the number of departures of the critical aircraft until the maximum aircraft CDF is equal to the value recorded in step 4). Record the equivalent number of departures of the critical aircraft;
- 7) adjust the critical aircraft weight to obtain a maximum CDF of 1.0 for the number of departures obtained at step 6). This is the maximum allowable gross weight (MAGW) for the critical aircraft;
- 8) compute the ACR of the critical aircraft at its MAGW. The value obtained is designated as PCR(i). (ACR computations must follow the procedure in 1.1.3);
- 9) if AC(i) is the maximum ACR aircraft from step 3) above, then skip to step 13);

- 10) remove the current critical aircraft AC(i) from the traffic list and re-introduce the other aircraft not previously considered as critical aircraft. The new aircraft list, which does not contain any of the previous critical aircraft, is referred to as the reduced aircraft list. Increment the index value ( $i = i+1$ );
- 11) compute the maximum CDF of the reduced aircraft list and select the new critical aircraft AC(i);
- 12) repeat steps 5-9 for AC(i). In step 6, use the same maximum CDF as computed for the initial aircraft mix to compute the equivalent number of departures for the reduced list; and
- 13) the PCR to be reported is the maximum value of all computed PCR(i). The critical aircraft is the aircraft associated with this maximum value of PCR(i).

1.1.4.5.4 A flowchart of the above procedure is shown in Figure 1-9. The purpose of steps 10 to 13 is to account for certain cases with a large number of departures of a short/medium-range aircraft (such as the B737) and a relatively small number of departures of a long-range aircraft (e.g. the A350). Without these steps, the smaller aircraft would generally be identified as critical, with the result that the PCR would require unreasonable operating weight restrictions on larger aircraft (unreasonable because the design traffic already included the large aircraft). Note that if the initial critical aircraft is also the aircraft in the list with the maximum ACR at operating weight, then the procedure is completed in one iteration, with no subsequent reduction to the traffic list.

1.1.4.5.5 The above procedure returns a uniquely determined PCR numerical value based on the identified critical aircraft.

#### 1.1.4.6 Applicability

1.1.4.6.1 The technical evaluation should be used when pavement characteristics and aircraft mix are consistently known and documented.

1.1.4.6.2 The PCR procedure does not dictate the use of a preferred subgrade failure/damage model or a method for treating the multi-axle loading.

#### *PCR procedure — Using aircraft experience (U)*

1.1.4.6.3 Whenever possible, reported pavement strength should be based on a “technical evaluation”. When, for economic or other reasons a technical evaluation is not feasible, evaluation can be based on experience with “using aircraft”. A pavement satisfactorily supporting aircraft using it, can accept other aircraft if they are no more demanding than the using aircraft. This can be the basis for an evaluation.

1.1.4.6.4 Techniques for “using aircraft” evaluation are given in 3.5.

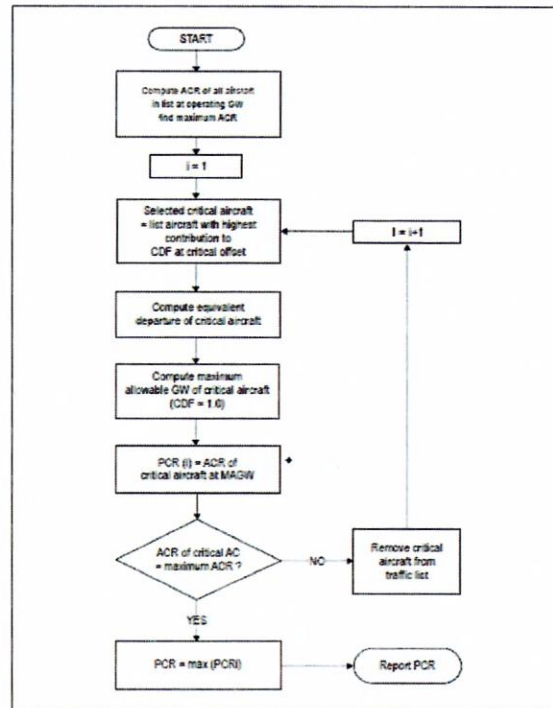

Figure 1-9. Flowchart of recommended PCR computation procedure

1.1.4.6.5 Worked examples:

Example 1 (Flexible)

**Steps 1 and 2:** Data collection:

- a) Pavement characteristics

The pavement description consists of providing for each layer its thickness, modulus of elasticity (E) and Poisson’s ratio (ν). For new pavement construction, the data should be those which served for the pavement design. For in-service pavement, it may be necessary to determine these input values by non-destructive testing (core sampling, heavy-weight deflectometer, etc.). Due to loading or environmental conditions, the pavement material characteristics may change over time. In the following example, the pavement was designed according to the French pavement design procedure, using standard French material specifications found in NF EN 13 108-1, for a period of usage of ten years. For PCR consistency, and to determine precisely the individual contribution of each aircraft in the mix to the maximum CDF, the same parameters that were used for the original pavement design (subgrade failure model, treatment of multi-axle loads, etc.) are also used to determine PCR. The evaluated pavement is a runway.





AIRCRAFT MIX ANALYSED				
No.	Aircraft model	Maximum taxi weight (t)	Annual departures	
1	A321-200	93.9	14 600	
2	A350-900	268.9	5 475	
3	A380-800	571	1 825	
4	B737-900	79.2	10 950	
5	B787-8	228.4	3 650	
6	B777-300ER	352.4	4 380	
PAVEMENT CHARACTERISTICS				
Layers	Designation	E-Modulus (MPa)	Poisson's ratio	Thickness (cm)
Surface course	EB-BBSG3	E=f(θ, freq.)	0.35	6
Base course	EB-GB3	E=f(θ, freq.)	0.35	18
Sub-base (1)	GNT1	600	0.35	12
Sub-base (2)	GNT1	240	0.35	25
Subgrade		80	0.35	∞

**Aircraft mix data**

For new pavement construction, the aircraft mix for PCR determination is the same aircraft list used for the pavement design.

For in-service pavement, the PCR analysis considers aircraft usage over the remaining pavement (structural) life. If the mixture of aircraft types using the pavement is known to have changed significantly from the design forecast, an updated aircraft list should be used. This example uses the following list of aircraft with maximum operating weights and annual departures:

*Note: The evaluated pavement is a runway; each aircraft is assigned a lateral wander of 1.5 m (standard deviation of 0.75 m). Each aircraft is centred on the pavement centreline and modelled with its real main landing gear coordinates.*

**Step 3: Aircraft ACR at operating weight:**

	B777-300ER	A321-200	A350-900	B787-8	B737-9	A380-800
Operating weight (t)	352.4	93.9	268.9	228.4	79.2	571
ACR	790	550	720	680	450	650



**Step 4:** CDF of the entire aircraft mix:

The CDF is computed for the entire fleet by summing the individual aircraft CDF contributions along a transverse axis perpendicular to the runway centreline. Figure 1-10 shows the individual aircraft contributions to CDF and the resulting total CDF of the mix. The maximum value of CDF is 1.153, located at an offset 4.9 m from the runway centreline. The contribution of each aircraft in the mix to the maximum CDF is plotted in Figure 1-10.

The maximum CDF is greater than 1.0, indicating that the pavement is under-designed for the traffic analysed.

*Note. It is important to distinguish the CDF contributions of each aircraft to the maximum CDF at the critical offset from the maximum damage due to individual aircraft (which may or may not occur at the critical offset).*

*For instance, the A321-200 damage contribution to the maximum CDF at the critical offset is 0.153 while its maximum damage is equal to 0.341. Similarly, the A350-900 produces a maximum damage of 0.306, lower than the A321, but its contribution to the maximum CDF is of 0.302, higher than the A321 contribution. The difference is due to different track dimensions (distance of the landing gear from the centreline) of the various aircraft.*

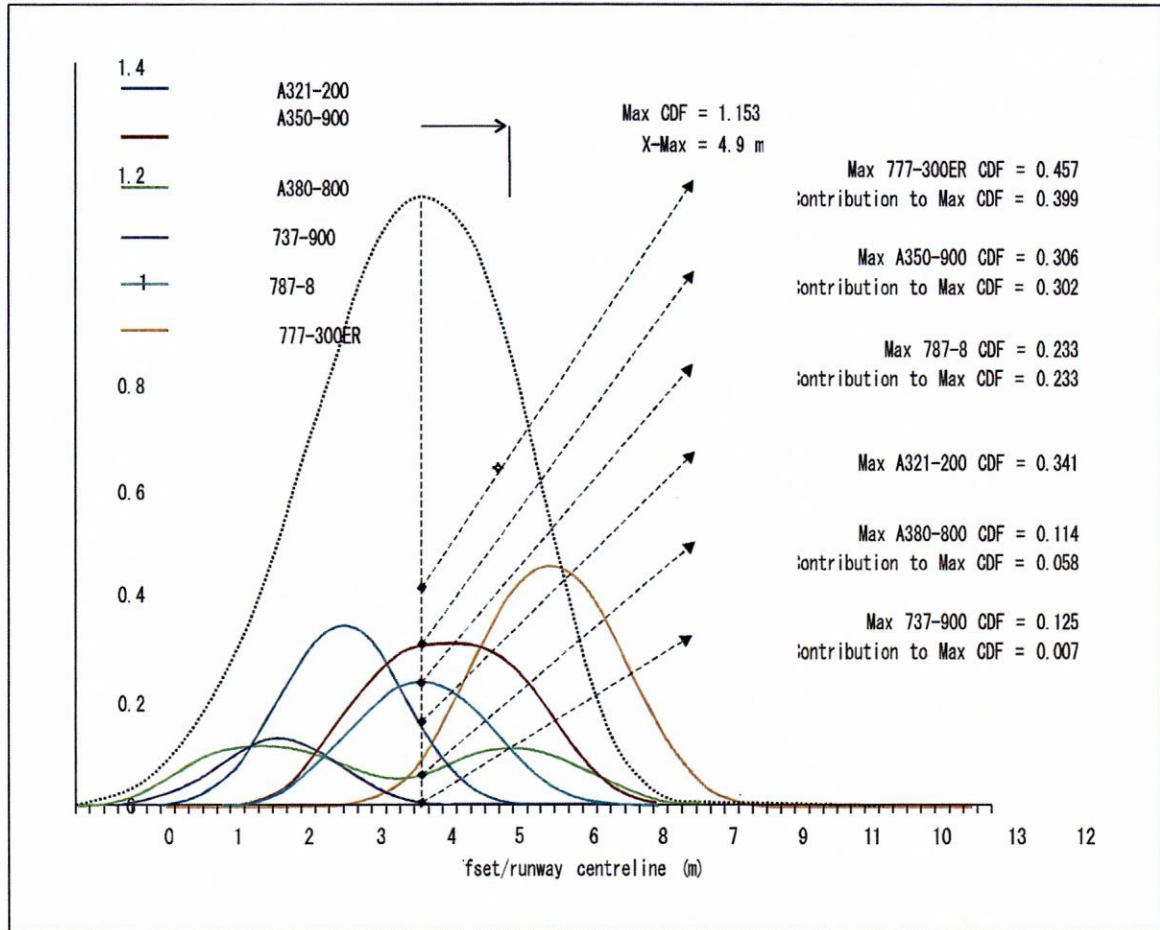

Figure 1-10. Aircraft CDF, total CDF and aircraft contribution to the maximum CDF

The aircraft with the highest CDF contribution (to the maximum CDF) becomes the most demanding aircraft within the mix. In this example, the highest contribution to the maximum CDF (0.399 — see Figure 1-10) is produced by the B777-300ER.

The aircraft with the highest CDF contribution (to the maximum CDF) becomes the most demanding aircraft within the mix. In this example, the highest contribution to the maximum CDF (0.399 — see Figure 1-10) is produced by the B777-300ER.





**Step 5:** The B777-300ER is selected as the most contributing aircraft to the maximum CDF. All other aircraft are removed.

**Step 6:** The contribution of the B777-300ER to the maximum CDF at its initial annual departure level is 0.457. The number of annual departures is adjusted until CDF equals 1.153. This step is performed by simple linear extrapolation, giving 11 050 equivalent annual departures of the B777-300ER (110 500 total departures).

**Step 7:** The gross weight of the B777-300ER is adjusted to obtain a maximum CDF of 1.0. In other words, the pavement is now correctly designed to accommodate the single equivalent aircraft at its adjusted weight and equivalent annual departure level. The MAGW is 341.3t.

**Step 8:** The B777-300ER ACR at its MAGW is 740/F/C.

**Step 9:** Checking against the list in Step 3, the B777-300ER is the maximum ACR aircraft. Therefore, the procedure is stopped. The PCR to be reported is equal to the B777-300ER ACR at its MAGW:

PCR 740 FCWT.

For the tire pressure code, the letter W is selected since the evaluated pavement is new construction, and the surface asphalt mix has been designed to resist the imposed tire pressures.

Example 2 (Flexible)

**Steps 1 and 2:** Data collection:

- a) Pavement characteristics

In this example, a flexible runway was designed according to the FAA pavement design procedure, using standard material specifications found in the United States FAA AC 150/5370-10. For PCR consistency, and to determine precisely the individual contribution of each aircraft in the mix to the maximum CDF, the procedure should consider the design parameters that served the original pavement design (subgrade failure model, treatment of multi-axle loadings, etc.). This is achieved in accordance with FAA AC 150/5320-6F, Airport Pavement Design and Evaluation.



PAVEMENT CHARACTERISTICS				
Layers	Designation	E-Modulus (MPa)	Poisson's ratio	Thickness (cm)
Surface course	P-401/P-403 HMA Surface	1379	0.35	10.2
Base course	P-401/P-403 (flex)	2758	0.35	12.7
Sub-base	P-209	467	0.35	17.5
Subgrade		200	0.35	infinite

b) Aircraft mix data

In this example, the traffic data represent a regional hub, in which there is a large number of departures of mid-range jet aircraft (A320, A321, B737) combined with a smaller number of operations of long-range or large aircraft (A330, B777 and A380). The design life is 20 years.

AIRCRAFT MIX			
No.	Aircraft model	Maximum taxi weight (t)	Annual departures
1	A330-300	233.9	52
2	B777-300ER	352.4	52
3	A380-800	571	52
4	B737-900ER	85.4	109 50
5	A320-200	77.4	10 950
6	A321-200	93.9	1 560

Note. Consistent with FAA design standards, the assumed standard deviation of aircraft wander is 0.776 metres (30.54 inches).

Step 3: Aircraft ACR at operating weight:

	A321-200	B737-900ER	B777-300ER	A320-200	A330-300	A380-800
Operating weight (t)	93.9	85.4	352.4	77.4	233.9	571
ACR	460	420	570	360	570	550

**Step 4:** CDF of the entire aircraft mix:

The CDF is computed for the entire fleet by summing the individual aircraft CDF contributions along a transverse axis perpendicular to the runway centreline. In this example, the computation was done using the FAA programme FAARFIELD 1.42.

Figure 1-11 shows the individual aircraft CDF and the resulting total CDF for the design. The maximum CDF is 0.99, located at a lateral offset 3.7 m from the runway centreline. The contribution of each aircraft in the mix to the maximum CDF is plotted in Figure 1-11. Note that the CDF values plotted in Figure 1-11 are based on aircraft characteristics for thickness design, according to which 95 per cent of the aircraft gross weight acts on the main gear. The maximum CDF is slightly less than 1.0, indicating that the pavement thickness is properly designed for the traffic analysed. When the characteristics are adjusted to reflect the mass and CG values that produce the highest main gear loads on each aircraft (see 1.1.3.2.6, then the maximum CDF is reduced to 0.898; however, the relative contributions of the aircraft are the same. In contrast to Example 1, the maximum CDF is concentrated around single-aisle aircraft, while the contribution of the long-range aircraft is less, due to the small number of annual departures.

**Step 5:** Based on Figure 1-11, the B737-900ER is selected as the most contributing aircraft to the maximum CDF. All other aircraft are removed.

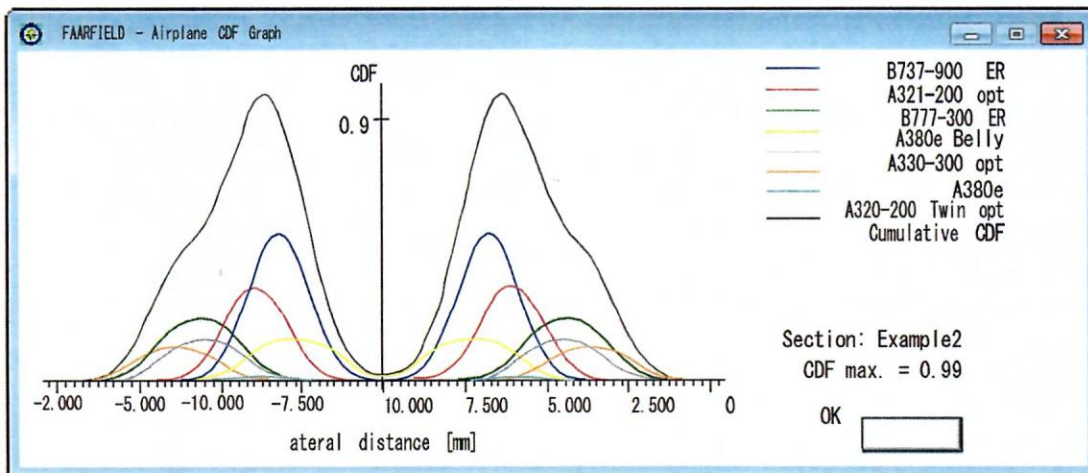

Figure 1-11. Aircraft CDF, total CDF and aircraft contribution to the maximum CDF

**Step 6:** The contribution of the B737-900ER to the maximum CDF at its initial annual departure level is 0.405. The programme adjusts the number of annual departures iteratively until CDF equals 0.898, giving 21 837 equivalent annual departures of the B737-900ER.





**Step 7:** The gross weight of the B737-900ER is adjusted to obtain a maximum CDF of 1.0. The pavement is now correctly designed to accommodate the single equivalent aircraft at its adjusted weight and equivalent annual departure level. The MAGW is 85.77 t.

**Step 8:** The ACR of the B737-900ER at its MAGW is 425 FA = PCR1.

**Step 9:** Checking against the table in Step 3, it is found that the B737-900ER is not the maximum ACR aircraft. Therefore, the procedure continues to Step 10.

**Step 10:** The B737-900ER is removed from the aircraft list, and all other aircraft are reintroduced.

**Step 11:** In the reduced aircraft mix, the most contributing aircraft is the A321-200, since the location of the maximum CDF has now changed by removing the B737-900ER.

**Step 12:** Steps 5 to 9 are repeated until the aircraft that is the highest contributor to CDF at the critical offset is also the maximum ACR aircraft. In this example, the recursive procedure is stopped at the third potential critical aircraft. The resulting PCR<sub>i</sub> values are:

- a) PCR1 425 FAWT (first critical aircraft, B737-900ER)
- b) PCR2 465 FAWT (second critical aircraft of the reduced aircraft mix, A321-200)
- c) PCR3 580 FAWT (third critical aircraft and maximum ACR aircraft, B777-300ER)

Retained PCR = maximum (PCR1, PCR2, PCR3) = 580 FAWT

Because the reported PCR is higher than the maximum operating weight ACR of any of the mix aircraft, there are no operating weight restrictions.

### Example 3 (Rigid)

**Steps 1 and 2:** Data collection:

- a) Pavement characteristics

In this example, a rigid taxiway is evaluated for PCR reporting. Material properties are assigned to layers following standard the material specifications found in FAA AC 150/5370-10 and FAA AC 150/5320-6F. For this example, assume that, based on laboratory tests, the flexural strength of the concrete is 4.5 MPa.



PAVEMENT CHARACTERISTICS				
Layers	Designation	E-Modulus (MPa)	Poisson's ratio	Thickness (cm)
Surface course	P-501 Portland cement concrete	27 579	0.15	45.0
Base course	P-401/P-403 (flexible)	2 758	0.35	12.5
Sub-base	P-209	311	0.35	30.0
Subgrade	P-152	90	0.40	infinite

b) Aircraft mix data

The applied traffic for this example is given in the table below. The design life is 20 years. For this traffic mix, the FAA standard thickness design requirement (FAARFIELD 1.42) is 45.6 cm of concrete. Therefore, the existing pavement thickness is slightly under-designed for the given traffic, consequently operating weight restrictions may be required for some of the heavier aircraft.

AIRCRAFT MIX ANALYSED				
No.	Aircraft model	Maximum taxi weight (t)	Per cent weight on main gear	Annual departures
1	B747-8	440.0	94.7	365
2	A350-900	268.9	94.8	5 475
3	B787-8	228.4	91.3	3 650
4	A321-200	93.9	94.6	14 600
5	B737-900	79.2	94.6	10 950
6	EMB-190	48.0	95.0	10 950

Note: Consistent with FAA design standards, the assumed standard deviation of aircraft wander is 0.776 metres (30.54 inches).



**Step 3:** Aircraft ACR at operating weight:

	B747-8	A350-900	B787-8	A321-200	B737-900	EMB-190
Operating weight (t)	440.0	268.9	228.4	93.9	79.2	48.0
ACR/R/C	910	920	870	660	550	290

**Step 4:** CDF of the entire aircraft mix:

The CDF is computed for the entire fleet by summing the individual aircraft CDF contributions along a transverse axis perpendicular to the runway centreline. In this example, the computation was done using the FAA programme FAARFIELD 1.42.

Using the aircraft data in Step 2, the maximum CDF for the given traffic mix is found to be 1.24, which is higher than the design target value 1.0. The maximum CDF is located at a lateral offset 4.7 m from the runway centreline. The aircraft that is the largest contributor to CDF at this critical offset is the A350-900.

Aircraft contribution to CDF at critical offset (4.7 m)	
Aircraft	CDF
B747-8 (Wing Gear)	0.023
B747-8 (Body Gear)	0.001
<b>A350-900</b>	<b>0.935</b>
B787-8	0.158
A321-200	0.124
B737-900	0.001
EMB-190	0.000
Total	1.242

**Step 5:** The A350-900 is selected as the most contributing aircraft to the maximum CDF. All other aircraft are removed.

**Step 6:** The contribution of the A350-900 to the maximum CDF at its initial annual departure level is 0.935. The programme adjusts the number of annual departures iteratively until CDF equals 1.24, giving 7 227 equivalent annual departures of the A350-900.





**Step 7:** The gross weight of the A350-900 is adjusted to obtain a maximum CDF of 1.0 for 7 227 annual departures. The MAGW is 270.4 t.

**Step 8:** The ACR of the A350-900 at its MAGW is  $906/R/C = PCR1$ .

**Step 9:** Checking against the table in Step 3, it is found that the A350-900 is also the maximum ACR aircraft. Therefore, the procedure jumps to Step 13 (end). Rounding the PCR numerical value to the nearest multiple of 10, the PCR to be reported is 910/R/C/W/T.

If the airport publishes this PCR, then minor operating weight restrictions will be required on the A350-900. Alternatively, the A350-900 could be allowed to operate under the overload



## Chapter 2

### GUIDANCE FOR OVERLOAD OPERATIONS

#### 2.1 CRITERIA SUGGESTED IN ANNEX 14, VOLUME I, ATTACHMENT A

2.1.1 Overloading of pavements can result either from loads too large or from a substantially increased application rate, or both. Loads larger than the defined (design or evaluation) load shorten the design life while smaller loads extend it. Pavement failures rarely happen due to a single excessive load, but rather due to the repetition of loads exceeding the load rating for which the pavement was designed (cumulative damage principle). The structural behavior of pavement is such that it can sustain a definable load for an expected number of repetitions during its design life. As a result, occasional minor overloading is acceptable, when expedient, with only limited loss in pavement life expectancy and relatively small acceleration of pavement deterioration. For those operations in which magnitude of overload and/or the frequency of use do not justify a detailed analysis, the following criteria are suggested:

- a) for flexible and rigid pavements, occasional movements by aircraft with ACR not exceeding 10 per cent above the reported PCR should not adversely affect the pavement; and
- b) the annual number of overload movements should not exceed approximately 5 per cent of the total annual movements, excluding light aircraft.

2.1.2 Such overload movements should not normally be permitted on pavements exhibiting signs of distress or failure. Furthermore, overloading should be avoided during any periods of thaw following frost penetration or when the strength of the pavement or its subgrade could be weakened by water. Where overload operations are conducted, the appropriate authority should review the relevant pavement condition regularly and should also review the criteria for overload operations periodically, since excessive repetition of overloads can cause severe shortening of pavement life or require major rehabilitation of pavement.

#### *Overload technical analysis*

2.1.3 Overloads in excess of 10 per cent may be considered on a case-by-case basis when supported by a more detailed technical analysis. When overload operations exceed allowances described in 2.1.1, a pavement analysis is required for granting the proposed additional loads, which was not scheduled in the initial pavement design. In those cases, the pavement analysis should determine how the overload operation contributes to the maximum CDF when it is mixed with the actual aircraft mix. Indeed, the ACR as a relative indicator, even if exceeding the



reported PCR, cannot predict how the overload aircraft will affect the pavement structural behaviour and/or its design life, since it will be strongly dependent of its offset to the location of the maximum CDF produced by the aircraft mix (critical offset).

2.1. 4 The pavement analysis would then mean determining the number of permitted overload operations so that the CDF of the entire aircraft mix, including the overload aircraft, remains in the tolerances agreed by the relevant authority.



### Chapter 3

## STRUCTURAL EVALUATION OF PAVEMENTS

### 3.1 GENERAL

The purpose of this chapter is to present guidance on the evaluation of pavements to those responsible for evaluating and reporting pavement bearing strength. Recognizing that responsible individuals may range from experienced pavement engineers to airfield managers not benefitting from the direct staff support of pavement behaviour experts, information included in this chapter attempts to serve the various levels of need.

### 3.2 ELEMENTS OF PAVEMENT EVALUATION

3.2.1 The behaviour of any pavement depends upon the native materials of 1) the site, which after levelling and preparation is called the subgrade, 2) its structure including all layers up through the surfacing, and 3) the mass and frequency of using aircraft. Each of these three elements must be considered when evaluating a pavement.

#### The subgrade

3.2.2 The subgrade is the layer of material immediately below the pavement structure, which is prepared during construction to support the loads transmitted by the pavement. It is prepared by stripping vegetation, levelling or bringing to planned grade by cut and fill operations, and compacting to the needed density. Strength of the subgrade is a significant element and this must be characterized for evaluation or design of a pavement facility, or for each section of a facility evaluated or designed separately. Soil strength and, therefore, subgrade strength is very dependent on soil moisture and must be evaluated for the condition it is expected to attain in situ beneath the pavement structure. Except in cases with high water tables, unusual drainage, or extremely porous or cracked pavement conditions, soil moisture will tend to stabilize under wide pavements to something above 90 per cent of full saturation. Seasonal variation (excepting frost penetration of susceptible materials) is normally small to none and higher soil moisture conditions are possible even in quite arid areas. Because materials can vary widely in type, the subgrade strength established for a particular pavement may fall anywhere within the range indicated by the four subgrade strength categories used in the ACR-PCR method. See Chapter 1 of this Guidance material and JCAR PART 14, Chapter 2.

The pavement structure

3.2.3 The terms “rigid” and “flexible” have come into use for identification of the two principle types of pavements.

The terms attempt to characterize the response of each type to loading. The primary element of a rigid pavement is a layer or slab of Portland cement concrete (PCC), plain or reinforced in any of several ways. It is often laid under a granular layer that contributes to the structure both directly and by facilitating the drainage of water. A rigid pavement responds “stiffly” to surface loads and distributes the loads by bending or beam action to wide areas of the subgrade.

The strength of the pavement depends on the thickness and strength of the PCC and any underlying layers above the subgrade. The pavement must be adequate to distribute surface loads so that the pressure on the subgrade does not exceed its evaluated strength. A flexible pavement consists of a series of layers increasing in strength from the subgrade to the surface layer. A series such as select material, lower sub-base, sub-base, base and a wearing course, is commonly used. However, the lower layers may not be present in a particular pavement. The pavements meant for heavy aircraft usually have a bituminous bound wearing course. A flexible pavement yields more under surface loading, merely accomplishing a widening of the loaded area and consequent reduction of pressure, layer by layer. At each level from the surface to subgrade, the layers must have strength sufficient to tolerate the pressures at their level. The pavement thus depends on its thickness over the subgrade for reduction of the surface pressure to a value that the subgrade can accept. A flexible pavement must also have thickness of structure above each layer to reduce the pressure to a level acceptable by the layer. In addition, the wearing course must be sufficient in strength to accept, without distress, the tire pressures of using aircraft.

### **Aircraft loading**

3.2. 4 The aircraft mass is transmitted to the pavement through the undercarriage of the aircraft. The number of wheels, their spacing, tire pressure and size determine the distribution of aircraft load to the pavement. In general, the pavement must be strong enough to support the loads applied by the individual wheels, not only at the surface and the subgrade but also at intermediate levels. For the closely spaced wheels of dual and dual-tandem legs, and for adjacent legs of aircraft with complex undercarriages, the effects of distributed loads from adjacent wheels overlap at the subgrade (and intermediate) level. In such cases, the effective pressures are those combined from two or more wheels and must be attenuated sufficiently by the pavement structure. Since the distribution of load by a pavement structure is over a much narrower area on a high strength subgrade than on a low strength subgrade, the combining effects of adjacent wheels is much less for pavements on high strength than on low strength subgrades. This is the reason why the relative effects of two aircraft types are not the same for pavements of equivalent design strength, and this is the basis for reporting pavement bearing strength by subgrade strength category. Within a subgrade strength category the relative effects of two aircraft types on pavements can be uniquely stated with good accuracy.

**Load repetitions and composition of traffic**

3.2. 5 It is not sufficient to consider the magnitude of loading alone. There is a fatigue or repetitions of load factor that should also be considered. Thus magnitude and repetitions must be treated together, and a pavement, which is designed to support one magnitude of load at a defined number of repetitions can support a larger load at fewer repetitions and a smaller load for a greater number of repetitions. It is thus possible to establish the effect of one aircraft mass in terms of equivalent repetitions of another aircraft mass (and type). Application of this concept permits the determination of a single (selected) magnitude of load and the level of repetitions to represent the effect of the mixture of aircraft using a pavement.

**Pavement condition survey**

3.2. 6 A particularly important adjunct to or part of the evaluation is a careful condition survey. The pavement should be closely examined for evidence of deterioration, movement, or change of any kind. Any observable pavement change provides information on effects of traffic or the environment on the pavement. Observable effects of traffic along with an assessment of the magnitude and composition of that traffic can provide an excellent basis for defining the bearing capacity of a pavement.

**3.3 ELEMENTS OF THE ACR-PCR METHOD****Pavement classification rating (PCR)**

3.3. 1 The pavement classification rating (PCR) is an index rating (1/50th) of the mass, expressed in kilograms, which an evaluation shows it can be borne by the pavement when applied by a standard (1.50 MPa tire pressure) single wheel. The PCR rating established for a pavement indicates that the pavement is capable of supporting aircraft having an aircraft classification rating (ACR) of equal or lower magnitude. The ACR in comparison to the PCR must be the aircraft ACR established for the particular pavement type and subgrade category of the rated pavement, as well as for the particular aircraft mass and characteristics.

**Pavement type**

3.3. 2 For purposes of reporting pavement strength, pavements must be classified as either rigid or flexible. A rigid pavement is that employing a PCC slab whether plain, reinforced, or pre-stressed and with or without intermediate layers between the slab and subgrade. Large precast slabs, which require crane handling for placement, can be classified as rigid when used in pavements. A flexible pavement is that consisting of a series of layers increasing in strength from the subgrade to the wearing surface. Composite pavements resulting from a



PCC overlay on a flexible pavement or an asphaltic concrete overlay on a rigid pavement, or those incorporating chemically (cement) stabilized layers of particularly good integrity, require care in classification. If the “rigid” element remains the predominant structural element of the pavement and is not severely distressed by closely spaced cracking, the pavement should be classified as rigid; otherwise, the flexible classification should apply. Where classification remains doubtful, designation as flexible pavement will generally be conservative. Since PCR is relative to paved surfaces, it should not be considered appropriate for unpaved surfaces (compacted earth, gravel, laterite, coral, etc.), surfaces built with bricks or blocks, and surfaces covered with landing mat and membrane surfaces. If some type of PCR is determined for these types of surfaces, only the “using aircraft” method should be followed. In such a case, the “pavement type” field should indicate the actual surface type. Alternatively, it may be classified as flexible for reporting; however, it must include a designation indicating that the surface is not actually a paved surface (Note to 2.6.6 a), JCAR PART 14. If the actual construction is composite or non-standard, a note should be included to that effect.



**Subgrade category**

3.3. 3 Since the effectiveness of aircraft undercarriages using multiple-wheels is greater on pavements founded on strong subgrades compared to those on weak subgrades, the problem of reporting bearing strength is complicated.

To simplify the reporting and permit the use of index values for aircraft and pavement classification ratings (ACR and PCR), the ACR-PCR method uses four subgrade strength categories. These are termed high, medium, low and ultra-low with prescribed ranges for the categories. It follows that, for a reported evaluation (PCR) to be useful, the subgrade category to which the subgrade of the reported pavement belongs must be established and reported. Normally, subgrade strength will have been evaluated in connection with original design of a pavement or later rehabilitation or strengthening. Where this information is not available, the subgrade strength should be determined as part of the pavement evaluation. Subgrade strength evaluation should be based on testing wherever possible. Where an evaluation based on testing is not feasible, a representative subgrade strength category must be selected based on soil characteristics, soil classification, local experience or judgment. Commonly, one subgrade category may be appropriate for an aerodrome. However, where pavement facilities are scattered over a large area and soil conditions differ from location to location, several categories may apply and should be assessed and so reported. The subgrade strength evaluated must be that in situ beneath the pavement. The subgrade beneath an aerodrome pavement will normally reach and retain a fairly constant moisture and strength despite seasonal variations. However, in the case of severely cracked surfacing, porous paving, high ground water or poor local drainage, the subgrade strength can reduce substantially during wet periods. Unpaved surfaces will be especially subject to moisture change. In areas of seasonal frost, a lower reduced subgrade strength can be expected during the thaw period where frost-susceptible materials are involved.

**Tire pressure category**

3.3. 4 Directly at the surface, the tire contact pressure is the most critical element of loading with little relation to other aspects of pavement strength. This is the reason for reporting permissible tire pressure in terms of tire pressure categories. Except for rare cases of spalling joints and unusual surface deficiencies, rigid pavements do not require tire pressure restrictions. However, pavements categorized as rigid that have overlays of flexible or bituminous construction must be treated as flexible pavements for reporting permissible tire pressure. Flexible pavements, which are classified in the highest tire pressure category must be of very good quality and integrity, while those classified in the lowest category need only be capable of accepting casual highway type traffic. While tests of bituminous mixes and extracted cores for quality of the bituminous surfacing will be most helpful in selecting the tire pressure category, no specific relations have been developed between test behaviour and

acceptable tire pressure. It will usually be adequate, except where limitations are obvious, to establish category limits only when experience with high tire pressures indicates pavement distress.

#### Evaluation method

3.3. 5 Wherever possible, reported pavement strength should be based on a “technical evaluation”. Commonly, evaluation is an inversion of a design method. Design takes into consideration the aircraft loading to be sustained and the subgrade strength resulting from preparation of the local soil, which then provides the necessary thicknesses and quality of materials for the needed pavement structure. Evaluation inverts this process. It begins with the existing subgrade strength, finds thickness and quality of each component of the pavement structure, and uses a design procedure pattern to determine the aircraft loading that the pavement can support. Where available, the design, testing and construction record data for the subgrade and components of the pavement structure can often be used to make the evaluation. Or, test pits can be opened to determine the thicknesses of layers, their strengths and subgrade strength for the purpose of evaluation. A technical evaluation can also be made based on measurements of the response of the pavement to load. Deflection of a pavement under static plate or tire load can be used to predict its behaviour. Also, there are various devices for applying dynamic loads to a pavement (e.g. heavy falling weight deflectometers (HFWD), potential adaptation of traffic speed deflectometers (TSD) and other emerging techniques used on airport pavements), observing its response and using this to predict its behaviour. When, for economic or other reasons, a technical evaluation is not feasible, evaluation can be based on experience with “using aircraft”. A pavement satisfactorily supporting aircraft already using the pavement, can accept other aircraft if they are no more demanding than the using aircraft. This can be the basis for an evaluation.

#### Pavements for light aircraft

3.3. 6 Light aircraft are those having a mass of 5 700 kg or less. These aircraft have pavement requirements less than that of many highway trucks. Technical evaluations of those pavements can be made but an evaluation based on using aircraft is satisfactory. It is worth noting that, at some airports, service vehicles such as fire trucks, fuel trucks or snow ploughs may be more critical than aircraft. Since nearly all light aircraft have single-wheel undercarriage legs, there is no need for reporting subgrade categories. However, since some helicopters and military trainer aircraft within this mass range have quite high tire pressures, limited quality pavements may need to have tire pressure limits established.

### 3.4 ASSESSING THE MAGNITUDE AND COMPOSITION OF TRAFFIC

#### General

3.4.1 Pavement bearing strength evaluations should address not merely an allowable load, but the repetitions use level for that load. A pavement that can sustain many repetitions of one load can sustain a larger load but for fewer repetitions. Observable effects of traffic, even those involving careful measurements in situ or on samples in controlled laboratory tests, unfortunately do not (unless physical damage is apparent ) permit a determination of the portion of the pavement's repetitions life that has been used or, conversely, is remaining. Thus, an evaluation leading to bearing capacity determination is an assessment of the pavement's total expected repetitions (traffic/load) life. Any projection of remaining useful life of the pavement will depend on a determination of all traffic sustained since construction or reconstruction.

#### Mixed loadings

3.4.2 Normally, it will be necessary to consider a mixture of loadings at their respective repetitions use levels. There is a strong tendency to rate pavement bearing strength in terms of some selected loading for the allowable repetitions use level and to rate each loading applied to a pavement in terms of its equivalent number of this basic loading. To do this, a relation is first established between the number of repetitions and the magnitude of the loading. In the case of evident physical damage, a pavement will already be in the last stages of its useful life. Such relations are variously established using combinations of theory or design methods and experience behaviour patterns or laboratory fatigue curves for the principle structural element of the pavement. Not all relations are the same, but the repetitions parameter may not be always effective. It needs only to be established in general magnitude and not in specific value.

Thus, fairly large variations can exist in the loading and repetitions relationship without serious differences in the resulting evaluation.

3.4.3 Using the curve for loading versus repetitions to failure, the failure repetitions for each loading can be determined and compared to that for the basic selected loading. From these comparisons, the equivalent number of the basic selected loading for single applications of any loading is determined (i.e. factors greater than one for larger loadings and less than one for smaller loadings). An explanatory example of this process follows:

- a) relate loading to failure repetitions, as illustrated in Figure 3-1;



Figure 3-1. Curve for loading versus repetitions to failure

b)  $L_4 - r_4$  for selected loads  $L$ , read repetitions  $r$  from curve;

$L_1 - r_1$

$L_2 - r_2$

$L_3 - r_3$

$L_4 - r_4$

c) choose  $L_3$  as the basic load; and

d) compute equivalent repetitions factor  $f$  for each load (see Table 3-1).

Table 3-1. Equivalent repetitions factor  $f$  for each load

<i>Load</i>	<i>Equivalent repetitions factor</i>
$L_1$	$f = \frac{r_1}{r_1}$ (a value less than 1)
$L_2$	$f = \frac{r_2}{r_2}$ (a value less than 1)
$L_3$	$f = \frac{r_3}{r_3} = 1$
$L_4$	$f = \frac{r_4}{r_4}$ (a value greater than 1)

By use of these factors, the accumulated effect of any combination of loads experienced or contemplated can be compared to the bearing strength evaluation in terms of a selected loading at its evaluated allowable repetitions use level.

### 3.5 TECHNIQUES FOR “USING AIRCRAFT” EVALUATION

3.5.1 While technical evaluation should be accomplished wherever possible, it is recognized that financial and circumstantial constraints will occasionally prevent this. Since it is most important to have completely reported bearing strength information and since using aircraft evaluation is reasonably direct and readily comprehensible, this is presented first in the following paragraphs.

#### Heaviest using aircraft

3.5.2 A pavement satisfactorily sustaining its using traffic can be considered capable of supporting the heaviest aircraft regularly using it and any other aircraft that has no greater pavement strength requirements. Thus, to begin an evaluation based on using aircraft, the types and masses of aircraft and number of times each operates in a given period must be examined. Emphasis should be on the heaviest aircraft regularly using the pavement. Support of a particularly heavy load, but only rarely, does not necessarily establish a capability to support equivalent loads on a regular repetitive basis (see 3.4).



**Pavement condition and behavior**

3.5.3 There must next be a careful examination of what effect the traffic of using aircraft is having on the pavement. The condition of the pavement in relation to any cracking, distortion or wear, and the experience with needed maintenance are of first importance. Age must be considered since overload effects on a new pavement may not yet be evident, while some accumulated indications of distress may normally be evident in a very old pavement. In general, however, a pavement in good condition can be considered to be satisfactorily carrying the using traffic, while indications of advancing distress show the pavement is being overloaded. The condition examination should take note of relative pavement behaviour in areas of intense versus low usage, such as in and out of wheel paths or most and least used taxiways, zones subject to maximum braking (e.g. taxiway turn-off, etc.). Note should also be taken of behaviour of any known or observable weak or critical areas such as low points of pavement grade, old stream crossings, pipe crossings where initial compaction was poor, structurally weak sections, etc. These will help to predict the rate of deterioration under existing traffic and thereby indicate the degree of overloading or of underloading. The condition examination should also focus on any damage resulting from tire pressures of using aircraft and the need for tire pressure limitations.

**Reference aircraft**

3.5.4 Studying of the types and masses of aircraft will indicate those which must be of concern in establishing a reference aircraft, and the condition survey findings will indicate whether the load of the reference aircraft should be less than that being applied or might be somewhat greater. Since load distribution to the subgrade depends somewhat on pavement type and subgrade strength, the particular reference aircraft and its mass cannot be selected until those elements of the ACR-PCR method, which are reported in addition to the PCR, have been established (see 3.3.2 and 3.3.3).

**Determination of the pavement type, subgrade strength and tire pressure categories**

3.5.5 The pavement type must be established as rigid or flexible. If the pavement includes a PCC slab as the primary structural element, it should be classified as rigid even though it may have a bituminous overlay resurfacing (see 3.3.2). If the pavement includes no such load-distributing slab, it should be classified as flexible.

3.5.6 The subgrade category must be determined as high, medium, low, or ultra-low strength. If modulus of elasticity test data are available for the subgrade, these can be used directly to select the subgrade category. Such data, however, must represent in situ subgrade conditions. Similar data from any surrounding structures on the

same type of soil and in similar topography can also be used. Soil strength data in almost any other form (such as CBR data) can be used to project an equivalent modulus of elasticity  $E$  for use in selecting the subgrade category. Information on subgrade soil strength may be obtainable from local road or highway agencies, or local agricultural agencies. A direct, though somewhat crude or approximate, determination of subgrade strength can be made from classification of the subgrade material and reference to any of many published correlations such as that shown in Figure 3-2. (Also see 3.3.3 and 3.2.2.) Chapter 1.1.4.4.4 gives equivalencies between CBR or module of subgrade reaction  $k$  and modulus of elasticity  $E$ .

3.5. 7 The tire pressure category must be determined as unlimited, high, medium or low. PCC surfacing and good to excellent quality bituminous surfacing can sustain the tire pressures commonly encountered and should be classified as unlimited pressure category with no limit on pressure. Bituminous surfacing of inferior quality and aggregate or earth surfacing will require the limitation of lower categories (see 3.3.4). The applicable pressure category should normally be selected based on experience with using aircraft. The highest tire pressure being applied, other than rarely, by using aircraft, without producing observable distress should be the basis for determining the tire pressure category.



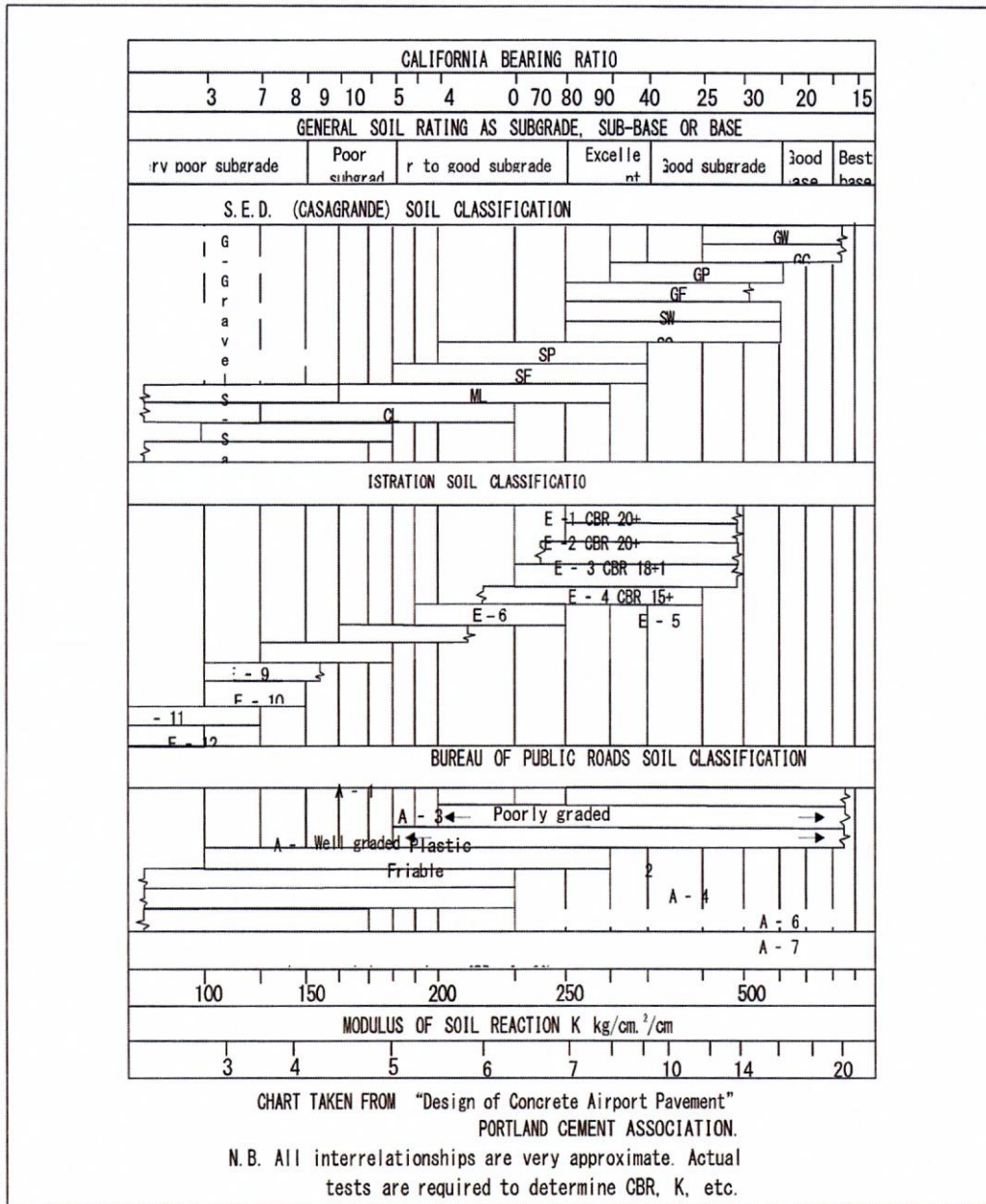

Figure 3-2. Interrelationships of soil classification, California Bearing Ratio (CBR) and k value

3.5. 8The most significant element of the using aircraft evaluation is the determination of the critical aircraft and the equivalent PCR for reporting purposes. Having determined the pavement type and the subgrade category, the next step would be the determination of the ACRs of aircraft using the pavement. For this purpose, needed information can be obtained by analysis using the prescribed ACR-PCR methods (see the ICAO-ACR



programme). Comparison of aircraft regularly using the pavements — at their operating masses — with the above-mentioned programme or the relevant aircraft characteristics documents will permit determination of the most critical aircraft using the pavement. If the using aircraft are satisfactorily being sustained by the pavement and there are no known factors indicating that substantially heavier aircraft could be supported, the ACR of the most critical aircraft should be reported as the PCR of the pavement. Thus, any aircraft having an ACR no higher than this PCR can use the pavement facility at a use rate (as repetitions per month) no greater than that of presently supported aircraft without shortening the use-life of the pavement.

3.5.9 In arriving at the critical aircraft, only aircraft using the pavement on a continuing basis without unacceptable pavement distress should be considered. The occasional use of the pavement by a more demanding aircraft is not sufficient to ensure its continued support even if no pavement distress is apparent.

3.5.10 As indicated, a PCR directly selected based on the evaluated critical aircraft loading examines an aircraft use intensity in the future similar to that at the time of evaluation. If a substantial increase in use (wheel load repetitions) is expected, the PCR should be adjusted downward to accommodate the increase. A basis for the adjustment, which relates load magnitude to load repetitions, is presented in 3.4.

#### **Pavements for light aircraft**

3.5.11 In evaluating pavements meant for light aircraft — 5 700 kg mass and less — it is unnecessary to consider the geometry of the undercarriage of aircraft or how the aircraft load is distributed among the wheels. Thus, subgrade class and pavement type need not be reported, and only the maximum allowable aircraft mass and maximum allowable tire pressure need to be determined and reported. For these, the foregoing guidance on techniques for “using aircraft” evaluation should be followed.

3.5.12 Because the 5 700 kg limit for light aircraft represents pavement loads only two-thirds or less of common highway loads, the assessment of traffic using pavements should extend to consideration of heavy ground vehicles, such as fuel trucks, fire trucks, snow ploughs, service vehicles, etc. These must also be controlled in relation to load limited pavements.

### **3.6 TECHNIQUES AND EQUIPMENT FOR “TECHNICAL” EVALUATION**

Technical evaluation is the process of defining or quantifying the bearing capacity of a pavement through measurement and study of the characteristics of the pavement and its behaviour under load. This can be done either by an inversion of the design process, using design parameters and methods, but reversing the process to



determine allowable load from existing pavement characteristics, or by a direct determination of response of the pavement to load by one of several means.

### 3.6.1 Pavement behaviour concepts for design and evaluation

Concepts of behaviour developed into analytical means by which pavements can be designed to accommodate specific site and aircraft traffic conditions are commonly referred to as design methods. There are a variety of concepts and many specific design methods. For example, several design and evaluation methods are presented in Chapter 4 of this Guidance material.

The early methods

3.6.1. 1 The early methods for design and evaluation of flexible pavements were experience-based and theory extended. They made use of index type tests to assess the strength of the subgrade and commonly to also assess the strength or contributing strength of base and sub-base layers. These were tests such as the CBR, plate bearing, and many others, especially in highway design.

3.6.1. 2 Early methods for design and evaluation of rigid pavements virtually all made use of the Westergaard model (elastic plate on a Winkler foundation), but included various extensions to treat fatigue, ratio of design stress to ultimate stress, strengthening effects of sub-base (or base) layers, etc. Westergaard developed methods for two cases, loading at the centre of a pavement slab (width unlimited) and loading at the edge of a slab (otherwise unlimited). While most rigid pavement methods use the centre slab load condition, some use the edge condition. These consider load transfer to the adjacent slab but means of treating the transfer vary. Plate bearing tests are used to characterize subgrade (or subgrade and sub-base) support, which is an essential element of these design methods. Once again, the early methods, further developed, remained the primary basis for aerodrome pavement design before the introduction of the linear elastic analysis and finite element method (FEM). The method previously adopted for aircraft classification number (ACN) determination is an example of these methods.

The newer — more fundamental — methods

3.6.1. 3 Continuing efforts to base pavement design on more fundamental principles has led to the development of methods using the stress-strain response of materials and rational theoretical models. The advances in computer

technology have made these previously intractable methods practical and led to computer-oriented developments not otherwise possible.

3.6.1. 4 The most popular theoretical model for the newer design methods is the elastic layered system. Layers are of finite thickness and infinite extent laterally except that the lowest layer (subgrade) is also of infinite extent downward. Response of each layer is characterized by its modulus of elasticity and Poisson's ratio. Values for these parameters are variously determined by laboratory tests of several types, by field tests of several types with correlations or calculated derivations, or merely by estimating values where magnitudes are not critical. These methods permit the stresses, strains, and deflections from imposed loads to be computed. Multiple loads can be treated by the superimposition of single loads. Commonly, the magnitude of strain at critical points (top of subgrade beneath load, bottom of surface layer, etc.) is correlated with intended pavement performance for use in design or evaluation. While these methods have been applied mostly to flexible pavements, there have also been applications to design of rigid pavements.

3.6.1. 5 While the elastic layered models are currently popular, it is recognized that the stress-strain response of pavement materials is non-linear. The layering permits variation of elastic modulus magnitude from layer to layer, but not laterally within each layer. There are developments that establish a stress dependence of the modulus of elasticity and use this dependence in finite element models of the pavement, through iterative computational means, to establish the effective modulus — element by element in the grid — and thereby produce a more satisfactory model. Also in this case, strains are calculated for critical locations and compared with correlations to expected behaviour. Finite element models are also being used to improve model-specific geometric aspects of rigid pavements, as has been incorporated in the FAA's rigid pavement design procedure.

Direct load response methods

3.6.1. 6 Theories applied earlier to pavement behaviour indicated a proportionality between load and deflection, thus implying that deflection should be an indicator of capacity of a pavement to support load. This also implied that pavement deflection determined for a particular applied load could be adjusted proportionately to predict the deflection, which would result from other loads. These were a basis for pavement evaluation. Field verification, both from experience and research, soon showed strong trends relating pavement behaviour to load magnitude and deflection and led to the establishment of limiting deflections for evaluation. There have since been many controlled tests and much carefully analysed field experience, which confirm a strong relation between pavement deflection and the expected load repetitions (to failure) life of the pavement subject to the load which caused that

deflection. However, this relation, though strong, is not well-represented by a single line or curve. It is a somewhat broad band within which many secondary factors appear to be having an impact.

3.6.1. 7 This established strong relation has been and is being used as the basis for pavement evaluation, but predominantly, until recently, applications have been to flexible pavements. Methods based on static and dynamic plate loading tests using plates up to a 75 cm diameter for static and from 30 to 45 cm for HFWD dynamic tests have been used. One source for guidance on evaluation and non-destructive testing using falling weight is presented in FAA Advisory Circular 150/5320-6 — Airport Pavement Design and Evaluation, and FAA Advisory Circular 150/5370-11 — Use of Non-destructive Testing in the Evaluation of Airport Pavements.

3.6.1. 8 Deflections under actual wheel loads (or between the duals of two- and four-wheel gear) are the basis of some expedient methods that closely parallel the plate methods. The Benkelman Beam methods, as well as other highway methods, are applicable to evaluation of pavements designed for light aircraft.

3.6.1. 9 There are a number of reasons why dynamic pavement loading equipment became popular. Static plate loads of wheel load magnitude are neither transportable nor easily repositioned. Dynamic loading applies a pulse load that better simulates the pulse induced by a passing wheel. But, most important was the development of sensors that could merely be positioned on the pavement or load plate and would measure deflection (vertical displacement). HFWDs with a falling mass apply loads in excess of the static mass and vary force magnitude by controlling the height of fall.

Pulses induced are repetitive but not steady, and the frequency is that which is adjusted to the device and pavement combination. The dynamic devices are applied in much the same manner as the static methods in 3.6.1.7. They can also be used to generate data on the stress-strain response of the pavement materials, as will be covered later in this section.

Essential inputs to pavement design methods

3.6.1. 10 The parameters that define the behaviour of elements (layers) of a particular pavement within the model, upon which its design is based, vary from the CBR, and other index type tests of the earlier flexible pavement methods and plate load tests of rigid pavement, as well as some flexible pavement methods to the stress-strain, modulus values, employed in the newer more fundamental methods.

3.6.1. 11 CBR tests for determining the strengths of subgrades, and of other unbound pavement layers for use in design or evaluation, should be as described in the particular method employed (France, United States, and other

countries), but generally will be as covered in ASTM D1883 or EN 13286, "Bearing Ratio of Laboratory Compacted Soils for Laboratory Test Determinations". Commonly, field-in-place CBR tests are preferable to laboratory tests whenever possible, and such tests should be conducted in accordance with the following guidance (from United States Military Standard 621A).

### 3.6.1. 12 Field-in-place CBR tests

a) These tests are used for design under any one of the following conditions:

1. when the in-place density and water content are such that the degree of saturation (percentage of voids filled with water) is 80 per cent or greater;
2. when the material is coarse-grained and without cohesion so that it is not affected by changes in the water content; or
3. when construction was completed several years before. In the last-named case, the water content does not actually become constant but appears to fluctuate within rather narrow ranges, and the field-in-place test is considered a satisfactory indicator of the load-carrying capacity. The time required for the water content to become stabilized cannot be stated definitely, but the minimum time is approximately three years.

b) Penetration:

Level the surface to be tested, and remove all loose material. Then follow the procedure described in ASTM D1883.

c) Number of tests:

Three in-place CBR tests should be performed at each elevation tested in the base course and at the surface of the subgrade. However, if the results of the three tests in any group do not show reasonable agreement, additional tests should be made at the same location. A reasonable agreement between three tests where the CBR is less than 10 permits a tolerance of 3; where the CBR is from 10 to 30, a tolerance of 5; and where the CBR is from 30 to 60, a tolerance of 10. For CBRs above 60, variations in the individual readings are not of particular importance. For example, actual test results of 6, 8 and 9 are reasonable and can be averaged as 8; results of 23, 18, and 20 are reasonable and can be averaged as 20. If the first three tests do not fall within the specified tolerance, three additional tests are made at the same location, and the numerical average of the six tests is used as the CBR at that location.

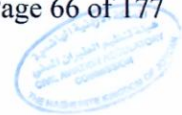

d) Moisture content and density:

After completion of the CBR test, a sample shall be obtained at the point of penetration for moisture content determination, and 10 to 15 cm away from the point of penetration for density determination.

3.6.1. 13 Plate load tests for determination of the modulus of subgrade reaction (k) to be used for evaluation or design of rigid pavements should be made in accordance with the procedures of the method employed, or can be as presented in ASTM D1196, "Non-Repetitive Static Plate Load Tests of Soils and Flexible Pavement Components, for use in Evaluation and Design of Airport and Highway Pavements" or in ASTM D1195, "Repetitive Static Plate Load Tests of Soils and Flexible Pavement Components, for Use in Evaluation and Design of Airport and Highway Pavements". The procedures also relate to flexible pavement design, as indicated by the titles of the ASTM standards.

3.6.1. 14 Conventional methods and values pertaining to the determination of modulus of elasticity, E, and Poisson's ratio,  $\nu$ , are used in depicting structural behaviour of the concrete layer in analyses of rigid pavement. Commonly,  $\nu$  is taken to be 0.15. The modulus, E, should be determined by testing the concrete and will normally be in the range of 25 000 to 30 000 MPa.

3.6.1. 15 Modulus of elasticity and Poisson's ratio values are needed for each layer of an elastic layered system and these can be determined in a variety of ways. Poisson's ratio is not a sensitive parameter and is commonly taken to be 0.3 to 0.33 for aggregate materials and 0.4 to 0.5 for fine grained or plastic materials. Since means of determining modulus of elasticity vary and because the stress-strain response of soil and aggregate materials is non-linear (not proportional), the values found for a particular material, by the various means, are not the same singular quantity that ideal theoretical considerations would lead one to expect. The following are some of the ways in which modulus of elasticity values can be determined for use in theoretical models (such as elastic layered) of pavement behaviour.

- a) Modulus of elasticity values for subgrade materials in particular, but also for other pavement layers — excepting bituminous or cemented materials — can be determined from correlations with index type strength tests. Most common has been correlation with CBR where:  $E = 10 \text{ CBR MPa}$ .
- b) Stress-strain response (modulus) can be determined by direct test of prepared or field-sampled specimens, but these are nearly always unsatisfactory. Response is too greatly affected by either preparation or sampling disturbance to be representative.

- c) It has been found that prepared specimens, and in some cases specimens from field samples, can be subjected to repeated loading to provide — after several to many load cycles — a reasonably representative modulus or stress-strain response curve. Modulus of elasticity so determined is referred to as resilient modulus and is currently strongly favoured, in some form, for layered elastic analyses. Tests can be conducted as triaxial tests, indirect tensile tests, even unconfined compression tests, and there may be others. Loadings can be regular wave forms (sinusoidal, etc.), but are commonly of a selected load pulse shape with delays between pulses to better represent passing wheels. Resilient modulus can be determined for bituminous materials by some of these tests and other similar tests, but temperature is most significant both for testing and application of the modulus for bituminous layers. Moduli for the various pavement layers are taken from these type tests and used directly in layered system analyses, but there are frequently problems or questions of validity.
- d) When dynamic plate load testing is carried out on existing pavements, it is possible to measure the velocity of propagation of stress waves within the pavements. Means have been developed for deducing the modulus of elasticity of each layer — generally excepting the top layer or layers — of the pavement from these velocity measurements. While moduli so determined are sometimes used directly in layered analyses, the determinations are for such small strains that values represent tangent moduli for curved stress-strain relations, while the moduli for higher (working strain) stress levels should be lower. Determinations by this means, adjusted by judgment or some established analytical means, are used.
- e) The subgrade modulus is the most significant parameter and some analyses use one of the above methods to determine a modulus for the subgrade and choose the moduli of other layers, either directly using the judgment basis or by some simple numerical process (such as twice the underlying layer modulus or one-half the overlying layer modulus), since precise values are not critical.
- g) By using selected or simplistically derived moduli for all layers except the subgrade, it is possible to compute a value for subgrade modulus using an elastic layered analysis and plate or wheel load deflections. This is done for some analyses.
- h) There is great interest currently in using the elastic layered theory and using field-determined deflections from dynamic load pavement tests for points beneath the centre of load and at several offset positions from the load centre. By iterative computer means, the moduli of the subgrade and several overlying layers

can be computed. Such computed moduli are then used in the layered model to compute strains at critical locations as predictors of pavement performance.

3.6.1. 16 Finite element methods permit formulation of pavement models that not only can provide for layering, but can treat non-linear (curved) stress-strain responses found for most pavement materials. Once again there is a requirement for Poisson's ratios and moduli of elasticity, but these must now be determined for each pavement layer as a function of the load or stress condition existing at any point in the model (on any finite element). Moduli relations are established from laboratory tests and most commonly by repeated triaxial load tests. Generally, these are of the following form but there are variants.

a. for granular materials:

$$M_r = E = K_1 \theta^{k_2}$$

Or

$$M_r = E = K_3 \sigma_3^{k_4}$$

b. for fine-grained soils:

$$M_r = E = K_5 \sigma_d^{k_6}$$

Where:

$M_r$	Resilient modulus
$E$	Modulus of elasticity
$\theta$	Bulk stress = $\sigma_1 + \sigma_2 + \sigma_3$
$\sigma_1, \sigma_2, \sigma_3$	Principal stresses
$\sigma_3$	Confining stress on the triaxial specimen
$\sigma_d$	Deviatoric stress = $\sigma_1 - \sigma_3$
$K_1, k_2, K_3, k_4, K_5, k_6$	Experimentally determined constants

### 3.6.2 Evaluation by inversion of design

To design a pavement one must select a design method, then determine the thicknesses and acceptable characteristics of materials for each layer and the wearing surface, taking into account the subgrade upon which the pavement will rest and the magnitude and intensity of traffic loading that must be supported. For evaluation, the process must be inverted since the pavement is already in existence. The character of the subgrade and thickness and the character of each structural layer including the surfacing must be established, from which the maximum allowable magnitude and frequency of allowable aircraft loading can be determined by using a chosen design method in reverse. It is not necessary that the design method selected for evaluation be the method by which the pavement was designed. The essential parameters that characterize behaviour of the various materials (layers) must be those which the chosen design method employed.

The method and elements of design

3.6.2. 1 The design method to be inverted for evaluation must first be chosen. Next, the elements of design inherent in the existing pavement must be evaluated in accordance with the selected design method.

- a) Thickness of each layer must be determined. This may be possible from construction records or may require the drilling of core holes or opening of test pits to permit measuring thickness.
- b) Subgrade strength and character must be determined. In this case, construction records may supply the needed information either directly or by a translation of the information to the form needed for theselected design method. Otherwise, it will be necessary to obtain the needed information from field studies. Reference to 3.6.1.9 to 3.6.1.14 will show the wide variety of ways in which subgrade behaviour is treated in the various design methods. Test pits may be necessary to permit penetration or plate testing or sampling of subgrade material for laboratory testing. Sampling or penetration testing in core holes may be possible. Dynamic or static surface load-deflection or wave-propagation testing may be required. Specific guidance must be gained from details of the design method chosen for use in the evaluation.
- c) The strength and character of layers between the subgrade and surface must also be determined. Problems are much the same as for the subgrade (see b) above) and guidance must come from the chosen design method.



- d) Most procedures for the design of rigid pavements require a modulus of elasticity and limiting flexural stress for the concrete. If these are not available from construction records, they should be determined by testing specimens extracted from the pavement (see ASTM C469 — modulus of elasticity and ASTM C683 — flexural strength). For reinforced or pre-stressed concrete layers, dependence must be placed on details of the individual selected design method.
- e) Bituminous surfacing (or overlay) layers must be characterized to suit the selected design method and to permit determination of any tire pressure limitation that might apply. Construction records may provide the needed information, otherwise testing will be required. Pavement temperature data may be required to help assess the stress-strain response or tire pressure effects on the bituminous layer.
- f) Any special consideration of frost effects by the selected design method or for the climate of the area need to be treated and the impact upon the evaluation determined.

The load repetition factor to which the pavement is subject is an important element of design and both past traffic sustained and future traffic expected may be factors in the evaluation. See 3.4 in relation to assessing traffic. For some design methods, it is sufficient to consider that the traffic being sustained adequately represents future traffic and the limiting load established by evaluation is for this intensity of traffic. This assumption is inherent in the translations between aircraft mass and ACR (or the reverse) of the ACR-PCR method. Many methods, however, require a load or stress repetitions magnitude as a basis for selection of a limiting deflection or strain that is needed for load limit evaluation.

From the chosen design method and established quantities for the design elements, limiting load or mass can be established for any aircraft expected to use the pavement.

**3.6.3 Direct or non-destructive evaluation**

Direct evaluation involves loading a pavement, measuring its response (usually in terms of deflection under the load and sometimes also at points offset from the load to show deflection basin shape) and inferring expected load support capacity from the measurements. Concepts are covered in 3.6.1.6, 3.6.1.7 and 3.6.1.8.





Static methods

3.6.3. 1 Static methods involve positioning plates or wheels, applying load and measuring deflections. Plate loads require a reaction against which to work in applying load while wheels can be rolled into position and then away. These direct methods depend on a correlation between pavement performance and deflection resulting from loading of the type indicated in Figure 3-3. A warning comment may be needed, since such correlations can be misinterpreted. They do not indicate the deflection that will be measured under the load after it has been applied for some number of repetitions as might be interpreted. Deflections of a pavement are essentially the same when measured early or late (following initial adjustment and before terminal deterioration) in its life. These correlations indicate the number of repetitions that can be applied to the pavement by the load which caused the deflection before failure of the pavement. Correlations are established by measuring the deflections of satisfactory pavements and establishing their traffic history. The expeditious deflection methods for evaluation described below are a good example of static methods.

Exeditious deflection methods

3.6.3. 2 Studies and observations by many researchers have shown a strong general correlation between the deflection of a pavement under a wheel load and the number of traffic applications (repetitions) of that wheel load, which will result in severe deterioration (failure) of the pavement (see Figure 3-3). These provide the basis for a simple expeditious means of evaluating pavement strength. Few references from studies and observations conducted in the early 1970s may still be possible to locate; but since the practice of measuring deflections under the landing gear of an actual aircraft towed on the pavement has practically disappeared with the advent of falling weight deflectometers in pavement testing, references to these more recent studies and observations typically cover correlations relative to dynamic methods of measurement (see 3.6.3.8).



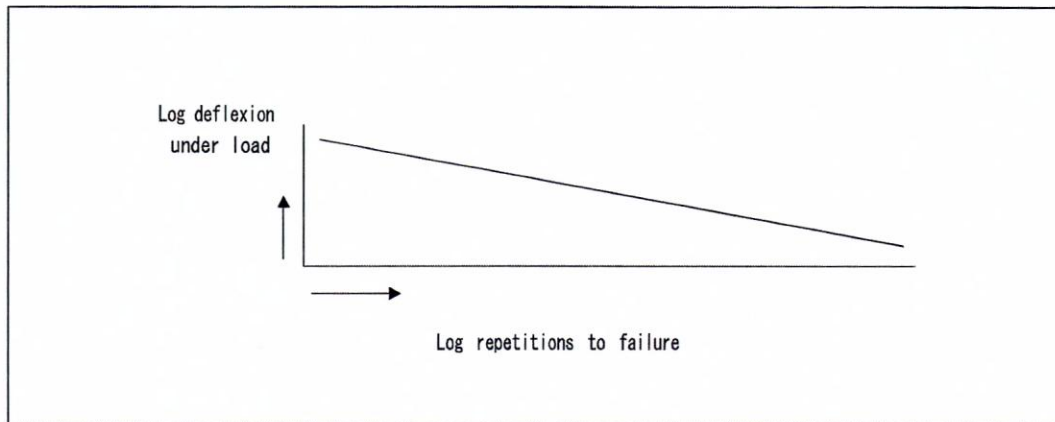

Figure 3-3. Correlation between the deflection of a pavement under load and the repetitions to failure

3.6.3.3 While the pattern of these relations is quite strong, the scatter of specific points is considerable. Thus, either the conservatism of a limiting curve or the low confidence engendered by the broad scatter of points or some combination must be accepted in using these relations for expeditious pavement evaluations. They do provide a simple relatively inexpensive means of evaluation. The procedure for such an evaluation is as follows:

- a) measure deflection under a substantial wheel load in a selected critical pavement location. Single or multiple wheel configurations can be used;
  1. position aircraft wheel in critical area;
  2. mark points along pavement for measurement, as indicated in Figure 3-4 a);
  3. using the “line-of-sight” method, take rod readings at each point;
  4. move aircraft away and repeat rod readings;
  5. plot difference in rod readings as deflections, as illustrated in Figure 3-4 b);
  6. connect points to gain an estimate of maximum deflection beneath tire;
- b) plot load versus maximum deflection, as illustrated in Figure 3-4 c);

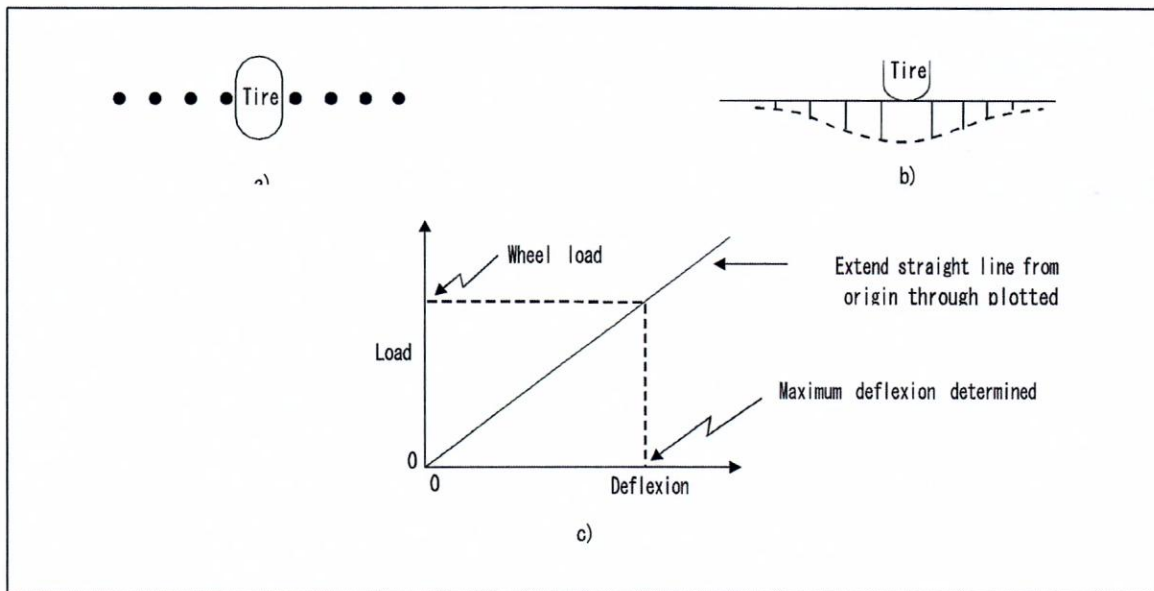

Figure 3-4.Relation between load and deflection

- c) combine the deflection versus failure repetitions curve with the above curve to provide an evaluation of pavement bearing strength for the gear used to determine deflection;
1. determine the repetitions of load (or equivalent repetitions as explained in 3.4), which must use the pavement before failure;
  2. from a correlation of the type shown in Figure 3-3, determine the deflection for the repetitions to failure;
  3. from the established relation of load to deflection of the type shown in Figure 3-4, determine the pavement bearing strength in terms of the magnitude of load allowable on the wheel used for the deflection measurements; and
- d) use the procedure described in Chapter 1 to find how the evaluated pavement bearing strength relates to the PCR. Aircraft with ACR no greater than this PCR can use the pavement without overloading it.

See ICAO-ACR computer programme for ACR versus mass information.

3.6.3. 4 A similar procedure can be followed using a jack and loading plate working beneath a jacking point of an aircraft wing or some equally suitable reaction load. The complete pattern of load versus deflection can be

determined and dial gauges mounted on a long reference beam can be used instead of optical survey methods. With provision of a suitable access aperture, the deflection directly beneath the centre of the load can be measured. Results can be treated on the same lines as those for a single wheel load.

3.6.3. 5 Methods used for highway load deflection measurements, such as the Benkelman Beam methods, can be used to develop deflection versus load patterns. Results are treated as indicated in Figure 3-4 to extrapolate loads to those of aircraft single-wheel loads, which with a relation as in Figure 3-3, permits evaluation of pavement bearing strength for single-wheel loads. From this, the limiting aircraft mass on pavements for light aircraft can be determined directly and reported in accordance with Chapter 1, 1.2. If unusually large loading plate or tire pressures are involved, it may be necessary to adjust between the single load characteristics used in the determination of the type indicated in Figure 3-4 (3.6.3.3 a)) and the reported limiting aircraft mass allowable or critical vehicle loads being compared to the limiting mass. Such adjustments can follow the procedures in any selected pavement design method. Limits on pavements for heavier aircraft can be determined as indicated in 3.6.3.3 d). It should be noted that extrapolation of load deflection relations (as in Figure 3-4 c)) from small load data taken on high strength pavements do not give good results. Unfortunately, the limits of extrapolation for good results are not established.

#### Dynamic methods

3.6.3. 6 These methods involve a dynamic loading device that is mounted for travel on a vehicle or trailer and which is lowered, in position, onto the pavement. Devices make use of counter-rotating masses, hydraulically actuated reciprocating masses, or falling weights (masses) to apply a series of pulses either in steady state by the reciprocating or rotating masses or attenuating by the falling mass. Most apply the load through a loading plate but some smaller devices use rigid wheels or pads. All methods make use of inertial instruments (sensors), which, when placed on the pavement surface or on the loading plate, can measure vertical displacement (deflection). The dynamic loading is determined usually by a load cell through which the load is passed on to the load plate. Comparison of the load applied and displacements measured provides load-deflection relations for the pavement tested. Displacements are always measured directly under the load, but are also measured at several additional points at specific distances from the centre of the load. Thus, load-deflection relations are determined not only for the load axis (point of maximum deflection) but also at offset points which indicate the curvature or shape (slope) of the deflection basin. The devices vary in size from some



highly developed, highway-oriented, units, which apply loadings of less than 1 000 kg to the large unit described in the United States FAA non-destructive test method referenced in 3.6.1.7. Some of the counter-rotating and reciprocating mass systems can vary the frequency of dynamic loading and some of these and the falling weight units can vary the applied load

3.6.3. 7 It is possible to measure the time for stress waves induced by the dynamic loading to travel from one sensor to the next, and to compute the velocity from this time and distance between sensors. Some dynamic methods make use of these velocity measurements to evaluate the strength or stress-strain response of the subgrade and overlying pavement layers for use in various design methods. Shear wave velocity, v, is related to modulus of elasticity,

E, by the relation:

$$v = \sqrt{\frac{1}{2(1 + \nu)} \frac{E}{\rho}} \quad (\text{Re. Barkan's "Dynamics of Bases and Foundations"})$$

Where Poisson's ratio, ν, can satisfactorily be estimated (see 3.6.1.13 and 3.6.1.14), and volumic mass, ρ, of the subgrade or pavement layer (sub-base to base) can be determined by measurement or satisfactorily estimated. Modulus values thus determined are used, either directly or with modification, in theoretical design models, or they are used with correlations to project subgrade and other layer strengths in terms of CBR, subgrade coefficient k, and similar strength index quantities. Sensors used in the velocity measurements may need to be located at greater distances from the load than when used to determine deflection basin shape. Also, the dynamic device must be capable of frequency variation since the various pavement layers respond at preferred frequencies, these must be found and dynamic load energy induced at the preferred frequency for determination of each layer's velocity of wave energy propagation.

Application of dynamic methods measurements

3.6.3.8 Falling weight deflectometers (FWD) and heavy weight deflectometers (HWD) provide an application for determining areas of a pavement system with consistent response to load. HFWDs are quick to use, relatively economical, and have become widely available. Note that some will offer "PCR" or other type results directly from the deflection data and a nominal pavement structure; however, the reliability of this practice is questionable due to the significantly different modulus assigned to each layer as a result of only minor differences in



deflections. The central and offset positions deflections and stress-wave velocities variously determined by the variety of dynamic equipment and methods in use are being applied for pavement evaluation in a number of ways:

- a) Direct correlations are made between the load-deflection in response to pavement and dynamic loading and pavement behaviour. The correlations are developed from dynamic load testing of pavements under which behaviour can be established.
- b) Measurements from dynamic methods, either directly or with extrapolation, can provide plate load information. This can serve as input — with suitable plate size or other conversions — to various methods. Used directly on subgrades or on other layers with established correlations, subgrade coefficients can then be determined for rigid pavement analyses.
- c) Shape of the deflection basin established from sensors placed at offsets from the load axis are used in some methods to reflect overall stiffness, and thereby load distributing character, of the pavement structure but direct use in establishing evaluation of load capacity has not been successful.
- d) Measured deflection under dynamic load is used to establish the effective modulus of elasticity of the subgrade in theoretical pavement models. The elastic constants (modulus and Poisson's ratio) for other layers are established by assumption or test and the subgrade modulus calculated using the load, the deflection measured and the pavement model, commonly the elastic layered theory.
- e) More recent developments involve the use of the elastic layered computer programmes. With an appropriate load applied, deflections are measured in the centre and at several offset locations. Then iterative computation means are used to establish elastic moduli for all layers of the pavement modelled.
- f) Theoretical models with elastic constants as in d) and e) above are used to calculate strain in flexure of the top layer beneath the load or vertical strain at the top of subgrade beneath the load, which locations are considered critical for flexible pavements. Stress or strain in flexure of a rigid pavement slab can be similarly calculated. These are compared to values of strain (or stress) from established correlations with pavement performance. Examples of these correlations have been documented since the late 1970s and can be found in pavement literature from the last 20 years.
- g) Stress-wave velocity measurements are used to establish pavement layer characteristics without sampling. Moduli of elasticity of pavement layers are derived from these measurements and used directly in



theoretical models or adjusted to better represent moduli at larger strains and used in the models. CBR values are derived from correlations between CBR and derived elastic moduli, commonly from  $E = 10$  CBR, in MPa. Modulus of subgrade reaction,  $k$ , and other such strength values could be similarly derived.



## Chapter 4

### STATE PRACTICES FOR DESIGN AND EVALUATION OF PAVEMENTS

*Note.— This chapter will be updated as individual States update their guidance regarding pavement evaluation during the implementation period of the ACR-PCR pavement strength reporting protocol.*

#### 4.1 PURPOSE

4.1.1 Aerodrome pavements are designed and constructed to provide adequate support for the loads imposed by aircraft and to produce a firm, stable, smooth, year-round, all-weather surface free of debris or other particles that can be blown or picked up by propeller wash or jet blast. To fulfil these requirements, the quality and thickness of the pavement must not fail under the imposed loads. The pavement must also possess sufficient inherent stability to withstand, without damage, the abrasive action of traffic, adverse weather conditions, and other deteriorating influences.

This requires coordination of many design factors, construction, and inspection to assure the best combination of available materials and workmanship.

4.1.2 The purpose of this chapter is to provide various State practices for pavement design and pavement evaluation, and the reporting of pavement strength

#### 4.2 PRACTICE OF FRANCE

##### 4.2.1 General

All the documents and guidance quoted in this section are available at the Directorate General of Civil Aviation (Direction Générale de l'Aviation Civile/Service Technique de l'Aviation Civile (DGAC/STAC) website, as well as other pavement design information, documentation, and software at [www.stac.aviation-civile.gouv.fr](http://www.stac.aviation-civile.gouv.fr)

##### 4.2.2 Pavement design

4.2.2.1 It is agreed among the international airfield pavement community that thickness design methods based only on empirical considerations have shown their limitations. Therefore, practices of France — as in many other

States — have moved towards more sophisticated and rational tools than the CBR design procedure for flexible pavements and the PCA method for rigid pavements (Portland Cement Association).

4.2.2 2 These new structural design tools include accurate descriptions of pavement structure layers in terms of thickness, material properties and binding conditions between layers. Intrinsic mechanical properties of pavement materials are used for both bituminous and cement-treated mixtures according to standards in Europe or France.

Moreover, variability and evolution of aircraft landing gears is addressed in the pavement design process through a full description of aircraft wheel gears (geometry, load, tire pressure).

4.2.2 3 This type of methodology is available for flexible pavement structures in the technical guidance “Rational design method for flexible airfield pavements — STAC”, associated with the Alizé-Airfield Pavement software for its application. Such guidance is also being developed for the design of rigid pavements and overlays. Meanwhile, in the transition period, the CBR and PCA procedures adapted to the context of France are still in use, as described in the Circular on Airfield Pavement Structural Design (Instruction sur le dimensionnement des chaussées d’aérodrome et la détermination des charges admissibles — STBA) and available for the application of the current ICAO ACN-PCN reporting method. (<https://www.stac.aviationcivile.gouv.fr/publications/dimensionnement-chaussees>).

#### 4.2.3 Pavement evaluation

4.2.3. 1 Evaluating the condition of existing pavements is a necessary task for airfield pavement managers so as to define rehabilitation programmes as accurately as possible. The civil aviation authority, provides a methodology for assessing airfield pavement condition based on visual surveys, allowing determining the Service Index (SI) (“Indice de service” (IS)) of the pavement, ranging from 0 (out of order) to 100 (no damage). Two sub-indices enable quantifying the surface condition as well as the structural condition of the pavement.

These indices are associated to threshold values defined so as to provide pavement managers with guidance on considering rehabilitation as soon as possible, in a near future, or at a later time. The complete methodology is described in the pavement condition index method (méthode indice de service — STBA).

4.2.3. 2 The use of heavy weight deflectometer (HWD) for structural evaluation of pavements is the trend that is fostered by CARC as well as pavement managers. Indeed, this equipment associated to an appropriate analysis tool gives an accurate description of the structural pavement condition. The “Guide to the evaluation of flexible



airfield pavements with an HWD” provides guidance for the evaluation of flexible pavements. Similar guidance is under development for rigid pavements.

### Reporting pavement strength

*Note.— This chapter will be further updated by the relevant States in accordance with the implementation of ACR-PCR.*

## 4.3 PRACTICE OF THE UNITED KINGDOM

### 4.3.1 Pavement design and evaluation

4.2.3. 1 It is the practice in the United Kingdom to design for unlimited operational use by a given aircraft, taking into account the loading resulting from interaction of adjacent landing gear wheel assemblies, where applicable. The aircraft is designated "the design aircraft" for the pavement. The support strength classification of the pavement is represented by the design aircraft's pavement classification number identifying its level of loading severity. All other aircraft ranked by the United Kingdom standards as less severe may see unlimited use of the pavement, though the final decision rests with the aerodrome authority.

4.2.3. 2 While there are now available a number of computer programmes based on plate theory, multilayer elastic theory and finite element analysis, for those wishing to have readily available tabulated data for pavement design and evaluation, the Reference Construction Classification (RCC) system has been developed from the British Load Classification Number (LCN) and Load Classification Group (LCG) systems. Pavements are identified as dividing broadly into rigid or flexible construction and analysed accordingly.

4.2.3. 3 For the reaction of aircraft on rigid pavements, a simple two-layer model is adopted. To establish an aircraft's theoretical depth of reference construction on a range of subgrade support values equating to the ICAO ACN/PCN reporting method, the model is analysed by the Westergaard centre case theory. Account is taken of the effect of adjacent landing gear wheel assemblies up to a distance equal to three times the radius of relative stiffness. This is considered essential in any new system in view of the increasing mass of aircraft, complexity of landing gear layouts and the possible interaction of adjacent wheel assemblies, especially on poor subgrades.

4.2.3. 4 To resolve practical design and evaluation problems, a range of equivalency factors appropriate to the relative strengths of indigenous construction materials is adopted in order to convert between theoretical model reference construction depths and actual pavement thickness.

4.2.3. 5 Aircraft reaction on flexible pavements follows the same basic pattern adopted for rigid pavement design and evaluation. In this case, a four-pavement model is analysed using the United States Corps of Engineers' development of the California Bearing Ratio (CBR) method. This includes Boussinesq deflection factors and takes into account interaction between adjacent landing gear wheel assemblies up to 20 radii distance. Practical design and evaluation problems are resolved using equivalency factors to relate materials and layer thicknesses to the theoretical model on which the reference construction depths for aircraft are assessed.

#### **4.3.2 Reporting pavement strength**

4.4.3. 1 The ICAO ACN/PCN reporting method for aircraft pavements is described in JCAR PART 14, 2.6. The critical aircraft is identified as the one that imposes a severity of loading condition closest to the maximum permitted on a given pavement for unlimited operational use. Using the critical aircraft's ACN, individual aerodrome authorities decide on the PCN to be published for the pavement concerned.

4.4.3. 2 Though not revealed by the ICAO ACN/PCN reporting method, when interaction between adjacent landing gear wheel assemblies affects the level of loading imposed by an aircraft, United Kingdom aerodrome authorities may impose restrictions on operations by a mass limitation or a reduction in the number of permitted movements. This is unlikely to occur, however, with aircraft currently in operational use, except where subgrade support values are poor.

### **4.4 PRACTICE OF THE UNITED STATES**

#### **4.4.1 General**

All the documents and guidance quoted in this section and relative to airport pavement design and construction are available through the FAA website [http://www.faa.gov/airports/engineering/pavement\\_design](http://www.faa.gov/airports/engineering/pavement_design) and airport design software at [https://www.faa.gov/airports/engineering/design\\_software/](https://www.faa.gov/airports/engineering/design_software/).

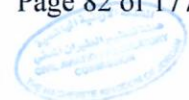



#### 4.4.2 Pavement design

4.4.2. 1 Pavement design guidance is presented in FAA Advisory Circular (AC) 150/5320-6 Airport Pavement Design and Evaluation. Design practice implements the layered elastic theory for flexible pavement design and the three-dimensional finite element theory for rigid pavement design. The FAA adopted these methodologies to address the impact of landing gear configurations and increased pavement load conditions on airport pavements. These procedures are robust and can address future gear configurations without modifying their underlying design procedures. The failure curves have been calibrated with full-scale pavement tests at the FAA National Airport Pavement Test Facility (NAPTF).

4.4.2. 2 The design methods are computationally intense, so the FAA developed a computer programme called FAARFIELD to help pavement engineers with their implementation. FAARFIELD may be downloaded at no cost from

<http://www.airporttech.tc.faa.gov/Products/Airport-Pavement-Software-Programs>

#### 4.4.3 Pavement evaluation

4.4.3. 1 Pavement evaluation guidance is presented in FAA AC 150/5320-6 Airport Pavement Design and Evaluation<sup>2</sup>. Airport pavement evaluations are used to assess the ability of an existing pavement to support different types, weights, or volumes of aircraft traffic. The load-carrying capacity of existing bridges, culverts, storm drains, and other structures are to be considered in these evaluations. Evaluations may also assist in determining the condition of existing pavements for use in the planning or design of improvements to the airport.

4.4.3. 2 Evaluation procedures are essentially the reverse of design procedures. This AC covers the evaluation of pavements for all weights of aircrafts.

#### 4.4.4 Reporting pavement strength

4.4.4. 1 Guidance for reporting pavement strength is presented in FAA AC 150/5335-5 Standardized Method of Reporting Airport Pavement Strength — PCN<sub>3</sub>. The AC provides guidance for use of the standardized method of reporting pavement strength, which applies only to pavements with bearing strengths of 5 700 kg (12 500 pounds) or greater. Determination of the numerical PCN value for a particular pavement can be based upon one of two procedures: the “using aircraft” method or the “technical evaluation” method. Guidance on both methods





is provided and either may be used to determine a PCN, but the methodology used must be reported as part of the posted rating. The posted rating of the PCN system uses the coded format described in JCAR PART 14 Volume I, 2.6.

---

<sup>2</sup> [http://www.faa.gov/airports/resources/advisory\\_circulars/index.cfm/go/document.current/documentNumber/150\\_5320-6](http://www.faa.gov/airports/resources/advisory_circulars/index.cfm/go/document.current/documentNumber/150_5320-6)  
<sup>3</sup> [http://www.faa.gov/airports/resources/advisory\\_circulars/index.cfm/go/document.current/documentNumber/150\\_5335-5](http://www.faa.gov/airports/resources/advisory_circulars/index.cfm/go/document.current/documentNumber/150_5335-5)





**Chapter 5**

**Page intentionally left blank**

---





**Chapter 6**

**Page intentionally left blank**

---



**Chapter 7****CONSIDERATIONS FOR CULVERTS, BRIDGES  
AND OTHER STRUCTURES****7.1 PURPOSE**

The purpose of this chapter is to provide basic information and guidance for design and concerns of aerodrome structures. Aerodrome structures, such as culverts and bridges, are usually designed to last for the foreseeable future of the aerodrome. Information concerning the landing gear arrangement of future heavy aircraft is speculative, however, it may be assumed, with sufficient confidence, that strengthening of pavements to accommodate future aircraft can be performed without undue problems. Strengthening of structures, however, may prove to be extremely difficult, costly, and time-consuming.

**7.2 GENERAL**

7.2.1 Structures for drainage or access commonly cross over pavements that support aircraft. Such facilities are subject to the added direct loading imposed by the aircraft, where point loadings may be increased, such as on bridges, overpasses, and subsurface terminal facilities where the entire aircraft weight may be imposed on a deck span, pier, or footing. However, more often, loading is indirectly transmitted to culverts and buried pipes through the soil layer beneath the pavement. These subsurface structures must be considered in connection when designing and when evaluating pavement strength. The patterns of stresses induced by surface wheel loads as they are transmitted downward are not the same on the subsurface structures as they are on the subgrade structures. This is not only because these structures are not at subgrade level, but also because the presence of the structure distorts the patterns.

7.2.2 When designing new facilities, care must be given to the structural adequacy of pipes, culverts, and bridged crossings, not only for the contemplated design loadings, but for possible future loadings to avoid a need for very costly corrective treatments made necessary by a growth in aircraft loadings.

**7.3 DESIGN CONSIDERATIONS**

7.3.1 For many structures, the design is highly dependent upon the aircraft landing gear configuration, therefore design should be for the largest aircraft at the maximum gross weight that could use the aerodrome over the life of the aerodrome. Consider all loading conditions, both dead and live loads, similar to those used by State and

local load and resistance factor design methodologies and programmes; such as the AASHTO LFRD used in the United States or the Structural Euro codes (standards EN-1990 through EN-1999) used in Europe. Suggested design parameters are provided in the following paragraphs.

#### Foundation Design

7.3.2 Foundation design will vary with soil type and depth. No departure from an accepted methodology should be anticipated; except that, for shallow structures, such as inlets and culverts, the concentrated loads may require heavier and wider spread footings than those presently provided by the structural standards in current use. For subsurface/buried structures, such as culverts, the following guidance is recommended:

- a. When the depth of fill is less than 0.6 m (2 ft), the wheel loads will be treated as concentrate loads.
- b. When the depth of fill is 0.6 m (2 ft) or more, wheel loads should be considered as uniformly distributed over a square with sides equal to 1.75 times the depth of the fill. When such areas from several concentrations overlap, the total load should be uniformly distributed over the area defined by the outside limits of the individual areas, but the total width of distribution should not exceed the total width of the supporting slab.
- c. For maximum wheel loads exceeding 11 400 kg (25 000 lbs), perform a structural analysis to determine the distribution of wheel loads at the top of the buried structure. Consider the maximum wheel loads, tire pressures and gear configuration that will act on top of the buried structure. The load distributions may be assumed conservatively in lieu of performing a detailed structural analysis.

#### Loads

7.3.3 All loads are to be considered as dead loads plus live loads. The design of structures subject to direct wheel loads should also anticipate braking loads as high as 0.7 G (for no-slip brakes).

#### Direct loading

7.3.4 Direct loading. Decks and covers subject to direct heavy aircraft loadings such as manhole covers, inlet grates, utility tunnel roofs, bridges, etc., should be designed for the following loadings:



- a) Manhole covers for 45 000 kg (100 000 lb) wheel loads with 1.72 MPa (250 psi) tire pressure. Higher tire pressures should be assumed if using aircraft greater than 1.72 MPa (250 psi).
- b) For spans of 0.6 m (2 ft) or less in the least direction, a uniform live load of the larger of 1.72 MPa (250 psi) or the maximum tire pressure assumed for manhole cover design.
- c) For spans of 0.6 m (2 ft) or greater in the least direction, the design will be based on the number of wheels that will fit the span. Design for the maximum wheel load anticipated.

7.3.5 Special consideration should be given to structures that will be required to support both in-line and diagonal traffic lanes, such as diagonal taxiways or apron taxi routes. If structures require expansion joints, load transfer may not be possible.





**Chapter 8**

**Page intentionally left blank**

---



## Chapter 9

### STRUCTURAL CRITERIA FOR NATURAL GROUND

#### 9.1 INTRODUCTION

9.1.1 In some cases, physical attributes of an aerodrome may not be paved but must still be capable of supporting the occasional passage of an aircraft. The natural ground in these instances may not have sufficient bearing strength to handle the aircraft, and therefore special preparation may be necessary. Adequate strength is required in order to ensure that no structural damage is sustained by an aircraft veering off onto the unpaved surface. The unpaved surface must also be capable of supporting any ground vehicles that may occasionally operate on the area.

9.1.2 The guidance provided in this section is geared toward the physical attributes most commonly left unpaved at an aerodrome. Specifically, these are runway and taxiway shoulders, runway end safety areas (RESAs) and runway strips outside the runway shoulder area. The guidance does not apply to unpaved runways themselves, since the strength requirements for a runway are much more stringent.

9.1.3 For any unpaved surface, the ingestion or jet blast of foreign object debris by aircraft turbine engines is an important consideration. The protection of the surface to ensure no loose material is allowed is the responsibility of the aerodrome. Some type of chemical treatment or the use of turf may be required for the unpaved surface, along with visual inspections, to ensure that foreign object debris is not present.

9.1.4 Attention is drawn to the fact that any bearing strength-related guidance provided in this chapter should in no way be interpreted as a design requirement. Such guidance is only to support the judgment of the engineer when no specific data is available.

#### 9.2 DESIGN BACKGROUND

9.2.1 In order to design for an unpaved area, several parameters must be known. The type of aircraft expected to operate at the aerodrome must be known, since the equivalent single wheel load of the main landing gear wheel arrangement is critical, as well as the tire pressure of the main gear tires. Knowing the expected aircraft coverages, along with the aforementioned aircraft parameters, will allow for the determination of the natural soil CBR required to support the aircraft loads without failure.





9.2.2 In most cases, the natural soil CBR is not sufficient to handle the larger aircraft wheel loads. The design methodology assumes a single layer of high-quality granular cover material, which can be added on top of the natural soil of low CBR in order to support the aircraft. The minimum CBR required for the granular cover layer is CBR 20. This CBR is typical for most granular sub-base materials used in flexible pavement construction and should be readily available. If the existing grade of the unpaved area needs to be maintained, the required thickness of low CBR natural soil can be removed and replaced by the high CBR cover layer. It is recommended that the natural soil CBR up to at least a depth of 60 cm be verified.

9.3 DESIGN DETAILS

9.3.1 The design methodology is based on previous work done by the United States Corps of Engineers, Waterways Experiment Station, for semi-prepared military airfields. A reformulation of the original CBR equation used in the design of flexible pavements can be used for determining the thickness of the required cover layer needed to support the natural soil in the unpaved area. The equation is:

t\_cover = (0.1275 x log C + 0.087) sqrt((P / (8.1 x CBR)) - (A / pi))

t\_cover = (0.1275 x log C + 0.087) sqrt((P x 27.556 / CBR) - (A / (6.4516 x pi)))

Imperial units

Metric units

(t=inches, A=sq inches)

(t=cm, A=sq cm)

C = coverages expected

P = equivalent single wheel load — function of gear geometry and thickness (lbs)

C = coverages expected

P = equivalent single wheel load — function of gear geometry and thickness (kN)

A = tire contact area (sq in)

A = tire contact area (sq cm)

tcover = thickness cover (in)

tcover = thickness cover (cm)

9.3.2 The design methodology is conservatively assumed to be ten passes of an aircraft. The failure criteria is 8 cm (3 inches) of rutting, but is based on rolling loads without aircraft braking effects. The ten-pass level was set





to allow a slightly stronger cover layer to counteract the aircraft braking loads. If heavy braking were to occur, then the expected rutting would be higher than the 8 cm failure criteria. However, an unpaved surface can be easily repaired by regrading and recompacting of the disturbed surface if required.

9.3.3 In order to provide broad technical guidance for aerodromes in the design of unpaved areas, a method similar to the PCN system was adopted. The same four subgrade categories used in the PCN system were adopted, since these are typical for most natural soil conditions to be expected at aerodromes worldwide. Additionally, three aircraft categories were assumed to be representative of the traffic that exists at the majority of aerodromes and are noted as follows:

Group 1: Regional aircraft with less than 13 600 kg wheel loads

Group 2: Narrow body aircraft with wheel loads between 13 600 to 20 410 kg

Group 3: Wide-body aircraft with wheel loads greater than 22 680 kg

9.3.4 The cover thicknesses noted in Table 9-1 are those of the layer of CBR 20 material or higher, needed to protect the subgrade type listed. For natural soil conditions with CBR values that fall between the four subgrade types, use linear interpolation to arrive at the required cover thickness. A layer of seeded top soil could be placed on top of the cover layer where needed to provide protection against erosion and foreign object debris (FOD) risk.

Table 9-1. Cover thickness required per subgrade type and aircraft group

Aircraft group	Cover thickness required per subgrade type			
	CBR 3	CBR 6	CBR 10	CBR 15
1	10 cm	8 cm	none	none
2	18 cm	13 cm	10 cm	8 cm
3	31 cm	20 cm	15 cm	13 cm





#### 9.4 GUIDANCE FOR BEARING STRENGTH OF PREPARED NATURAL GROUND AREAS

##### *Runway and taxiway shoulders*

9.4.1 The purpose of the shoulder is to provide adequate strength in order to support an aircraft in the event of an aircraft veer-off. The design guidance provided in Table 9-1 is sufficient for the design of an unpaved shoulder.

##### *Runway end safety areas (RESA)*

9.4.2 The purpose of the RESA is to provide adequate strength in the event of an aircraft undershooting or overrunning the runway. If there is a need to provide a better resistance and facilitate aircraft deceleration, adding a layer of lesser strength granular material may be an option. However, consideration should be given to the preparation and maintenance of such a granular layer.

##### *Runway strips*

9.4.3 The graded runway strip out to the shoulder should be of adequate strength to provide drag to an aircraft and facilitate deceleration in the event of an aircraft leaving the runway. The upper surface may be 15 cm of lesser strength material and the underlying natural soil of adequate strength to support the aircraft for one pass, such that structural damage does not occur.



## Appendix 1

AIRCRAFT CHARACTERISTICS AFFECTING  
PAVEMENT BEARING STRENGTH

## 1. GENERAL

1.1 This appendix describes those characteristics of aircraft which affect pavement strength design, namely: aircraft weight; percentage load on nose wheel; wheel arrangement; main leg load; tire pressure; and contact area of each tire. Table A1-1 (located at the end of this appendix) contains these data for most of the commonly used aircraft.

1.2 Aircraft loads are transmitted to the pavement through the landing gear, which normally consists of two main legs and an auxiliary leg, the latter being either near the nose (now the most frequent arrangement) or near the tail (older system).

1.3 The portion of the load imposed by each leg will depend on the position of the CG with reference to the three supporting points. The static distribution of the load by the different legs of a common tricycle landing gear may be illustrated in Figure A1-1 as follows:

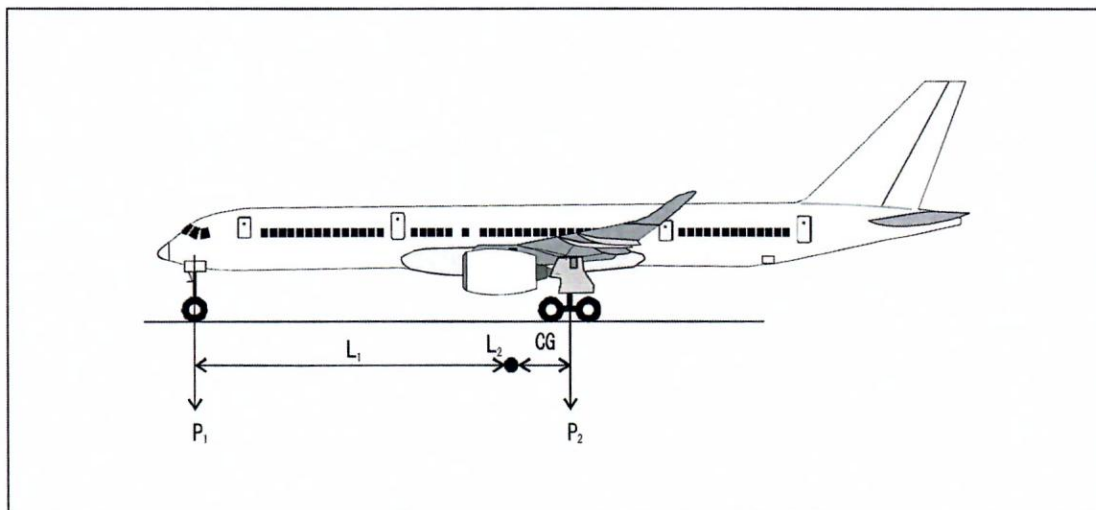

Figure A1-1. Aircraft weight distribution on ground



Where  $W$  is the aircraft weight;  $P_1$  the load transmitted by the auxiliary leg;  $P_2$  the load transmitted by both main legs;  $L^1$  and  $L^2$  the distance measured along the plane of symmetry from the CG to  $P^1$  and  $P^2$  respectively,

Then:

$$W = P_1 + P_2$$

$$P_1 L_1 = P_2 L_2$$

Therefore:

$$P_2 = P_1 \frac{L_1}{L_2}$$

1.4 The ratio  $L_1 / L_2$  is usually around 9 (i.e. the auxiliary leg accounts for approximately 10 per cent of the aircraft gross weight). Therefore, each main leg imposes a load equal to about 45 per cent of that weight. Wheel base and track width have not been included, since these dimensions are such that there is no possibility of interaction of the stresses imposed by the different legs of the landing gear.

1.5 From the above considerations, it can be seen that the characteristics of each main leg provide sufficient information for assessing pavement strength requirements. Accordingly, the table confines itself to providing data thereon.

1.6 The load supported by each leg is transmitted to the pavement by one or several rubber-tired wheels. The wheel arrangements shown in Figure A1-2 can be found on the main legs landing gear of civil aircraft currently in service.

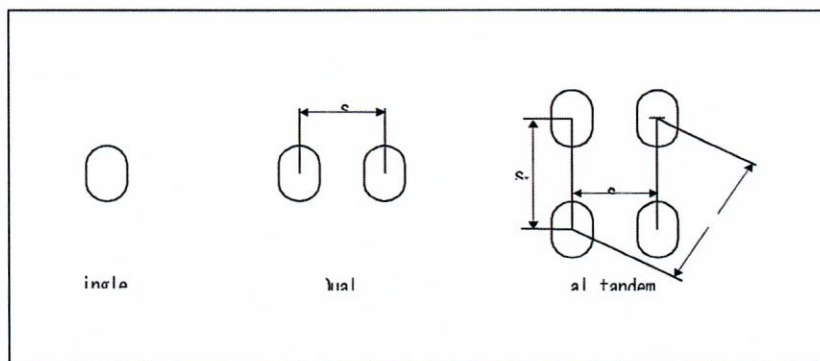

Figure A1-2. Wheel arrangements

1.7 For pavement design and evaluation purposes, the following wheel spacings are significant and therefore listed in the table:

S — distance between centres of contact areas of dual wheels

ST — distance between axes of tandem wheels

SD — distance between centres of contact areas of diagonal wheels and is given by the following expression:

$$S_D = \sqrt{(S^2 + S_T^2)}$$

*Note.— Tire pressures given are internal or inflation pressures.*

1.8 It should be noted that throughout the table, figures refer to the aircraft at its maximum take-off weight. For lesser operational weights, figures quoted for “load on each leg” and “contact area” should be decreased proportionally.

## 2. AIRCRAFT CHARACTERISTICS FOR DESIGN AND EVALUATION OF PAVEMENTS

2.1 The aircraft listed in Table A1-1 are representative of the aircraft manufacturers’ most current commercial aircraft types, typically carrying 70 passengers or greater or having a mass exceeding 40 tons. Aircraft in this weight range are the most demanding in terms of pavement loading. Table A1-1, in most cases, lists the heaviest version of an aircraft model; more detailed information can be found in the aircraft manufacturers’ aircraft characteristics for airport planning documents.

2.2 Wheel arrangement nomenclature (used in Table A1-1)

2.2.1 **Basic name for aircraft gear geometry.** Under the naming convention, abbreviated aircraft gear designations may include two variables, the main gear configuration and the body/belly gear configuration, if body/belly gears are present. Figure A1-3 illustrates the two primary variables.

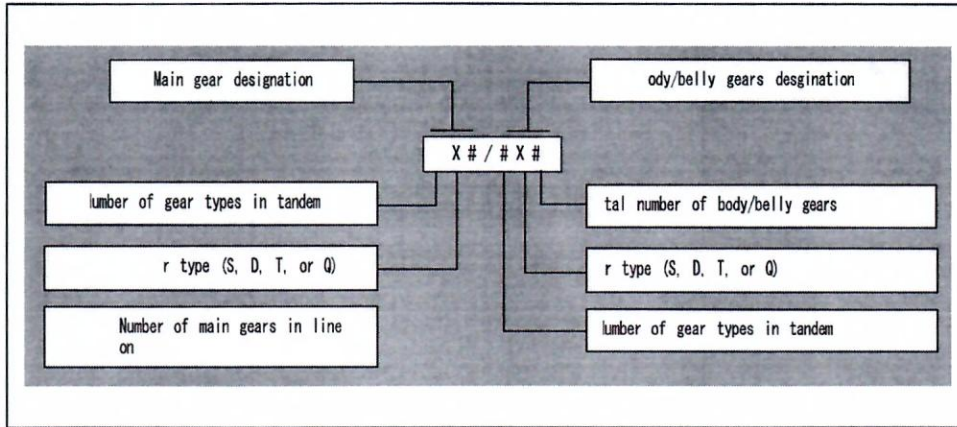

Figure A1-3. Gear naming convention

**2.2. 2 Basic gear type.** Gear type for an individual landing strut is determined by the number of wheels across a given axle (or axle line) and whether wheels are repeated in tandem. There may exist, however, instances in which multiple struts are in close proximity and are best treated as a single gear, e.g. Antonov AN-124 (see Figure A1-4). If body/belly gears are not present, the second portion of the name is omitted. For aircraft with multiple gears, such as the B747 and the A380, the outer gear pair is treated as the main gear.

**2.2. 3 Basic gear codes.** This naming convention, as shown in Figure A1-4, uses the following codes for gear designation purposes: single (S); dual (D); triple (T); and quadruple (Q).



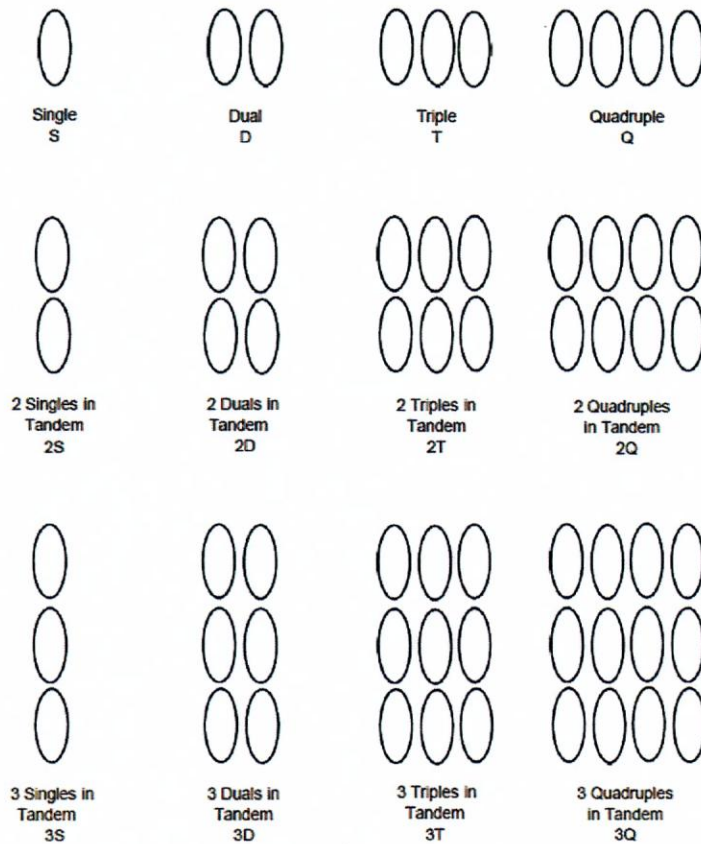

Figure A1-4. Generic gear configurations (increase numeric value for additional tandem axles)

2.2. 4 **Main gear portion of gear designation.** The first portion of the aircraft gear name comprises the main gear designation. This portion may consist of up to three characters.

- a) **First character** indicates the number of tandem sets or wheels in tandem (e.g. “3D” represents three dual gears in tandem). If a tandem configuration is not present, the leading value of “1” is omitted. Typical codes are: “S” representing single; “2D” representing two dual wheels in tandem; “5D” representing five dual wheels in tandem; and “2T” representing two triple wheels in tandem.
- b) **Second character** of the gear designation indicates the gear code (S, D, T or Q).



- c) **Third character** of the gear designation is a numeric value that indicates multiples of gears. For the main gear, the gear designation assumes that the gear is present on both sides (symmetrical) of the aircraft and that the reported value indicates the number of gears on one side of the aircraft. A value of 1 is used for aircraft with one gear on each side of the aeroplane. For simplicity, a value of 1 is assumed and is omitted from the main gear designation. Aircraft with more than one main gear on each side of the aircraft and where the gears are in line will use a value indicating the number of gears in line.

**2.2. 5 Body/belly gear portion of gear designation.** The second portion of the aircraft gear name is used when body/belly gears are present. If body/belly gears are present, the main gear designation is followed by a forward slash (/), followed by the body/belly gear designation. For example, the B-747 aircraft has a two dual wheels in tandem main gear and two dual wheels in tandem body/belly gears. The full gear designation for this aircraft is 2D/2D2. The body/belly gear designation is similar to the main gear designation, except that the trailing numeric value after the gear type (S, D, T or Q) denotes the total number of body/belly gears present (e.g. 2D1 = one dual tandem body/belly gear; 2D2 = two dual tandem body/belly gears). Because body/belly gear arrangements may not be symmetrical, the gear code must identify the total number of gears present and a value of 1 is not omitted if only one gear exists.

**2.2. 6 Unique gear configurations.** The Lockheed C-5 Galaxy has a unique gear type and is difficult to name using the proposed method. This aircraft will not be classified using the new naming convention and will continue to be referred to directly as the C5. Gear configurations such as those on the Boeing C-17, Antonov AN-124, and Ilyshin IL-76 might also cause some confusion. In these cases, it is important to observe the number of landing struts and the proximity of the struts. In the case of the AN-124, it is more advantageous to address the multiple landing struts as one gear (i.e. 5D or five duals in tandem) rather than use D5 or dual wheel gears with five sets per side of the aircraft. Due to wheel proximity, the C-17 gear is more appropriately called a 2T, as it appears to have triple wheels in tandem. In contrast, the IL-76 has considerable spacing between the struts and should be designated as a Q2.

**2.2. 7 Examples of gear geometry naming convention.** Figure A1-4 provides examples of generic gear types in individual and multiple tandem configurations

**Table A1-1. Aircraft characteristics for design and evaluation of pavements**

*Note 1.— This table has been prepared in metric units. To convert from kilogram to newton, multiply by 9.80665.*

Note 2.— Figures refer to the aircraft at its maximum take-off weight. For lesser operational weights, figures quoted for “load on each leg”, “tire-pressure” and/or “contact area” should be decreased proportionally.

Aircraft type	All-up mass (kg)	Load on one main gear leg (%)	Wheel arrangement	MAIN LEGS OF LANDING GEAR					Additional data for complex wheel arrangement
				Load on each leg (kg)	Tire pressure (MPa)	Wheel spacing (cm)			
						(S)	(S <sub>i</sub> )	(S <sub>D</sub> )	
A300 B2	142 900	47.0	2D	67 118	1.28	89	140	165.6	
A300 B4	165 900	47.0	2D	77 921	1.46	93	140	167.7	
A300-600 B4	165 900	47.1	2D	78 216	1.28	93	140	167.7	
A300-600R B4	172 600	47.5	2D	81 988	1.34	93	140	167.7	
A300-600R B4F	172 600	47.5	2D	81 988	1.34	93	140	167.7	
A300-600R F4	171 400	47.5	2D	81 418	1.34	93	140	167.7	
A310-200	144 900	46.6	2D	66 243	1.33	93	140	167.7	
A310-200F	142 900	46.6	2D	66 662	1.33	93	140	167.7	
A310-300	164 900	47.2	2D	77 873	1.29	93	140	167.7	
A310-300F	164 900	47.2	2D	77 873	1.29	93	140	167.7	
A318-100	68 400	44.5	D	30 431	1.24	93			
A319-100	75 900	45.8	D	34 746	1.38	93			
A319 CJ	76 900	45.8	D	35 181	1.38	93			
A319neo	75 900	45.8	D	34 746	1.38	93			
A320-100	68 400	47.1	D	32 215	1.28	93			
A320-200	78 400	46.4	D	36 405	1.44	93			
A320neo	79 400	46.3	D	36,757	1.44	93			
A320-200 (2D)	73 900	47.0	2D	34,969	1.22	78	101	127.5	
A321-100	89 400	47.5	D	42,432	1.46	93			
A321-200	93 900	47.6	D	44,717	1.50	93			
A321neo	93 900	47.6	D	44,717	1.50	93			
A330-200	242 900	46.3	2D	112,515	1.47	140	198	242.4	
A330-200F	233 900	47.3	2D	110,674	1.42	140	198	242.4	





MAIN LEGS OF LANDING GEAR

Aircraft type	All-up mass (kg)	Load on one main gear leg (%)	Wheel arrangement	Load on each leg (kg)	Tire pressure (MPa)	Wheel spacing (cm)			Additional data for complex wheel arrangement
						(S)	(Si)	(So)	
A330-800neo	242 900	46.3	2D	112,515	1.47	140	198	242.4	
A330-300	242 900	46.9	2D	113 896	1.49	140	198	242.4	
A330-900neo	242 900	46.9	2D	113 896	1.49	140	198	242.4	
A340-200	275 900	39.2	2D/D1	108 219	1.49	140	198	242.4	
A340-300	277 400	39.4	2D/D1	109 190	1.49	140	198	242.4	
A340-500	375 200	31.9	2D/2D1	119 675	1.61	140	198	242.4	
A340-500 HGW	381 200	31.6	2D/2D1	120 592	1.61	140	198	242.4	
A340-600	369 200	32.2	2D/2D1	118 930	1.61	140	198	242.4	
A340-600 HGW	381 200	31.7	2D/2D1	121 016	1.61	140	198	242.4	
A350-900	275 900	46.9	2D	129 326	1.68	173.5	204	267.8	
A350-1000	308 900	47.1	3D	145 427	15.2	140 F 147 C 140 R	140	313.0	
A380-800 (Wing gear)	577 000	18.9	2D	108 847	1.50	135	170	217.1	Full aircraft wheel arrangement 3D/2D2
A380-800 (Body gear)	577 000	28.3	3D	163 271	1.50	153 F 155 C 153 R	170	372.8	Full aircraft wheel arrangement 3D/2D2
A400M	141 400	46.9	3D	66 368	0.95	86	157 F 156 R	325.0	
An-12	64 000	46.3	2D	29 651	0.83	123	49.2	132.5	
An-22	227 500	43.6	3D	99 076	0.49	115	250	275.2	
An-24	21 000	46.6	D	9 786	0.49	50			
An-72-100	35 150	47.2	2S	16 591	0.59		126		
An-74TK-300	37 850	46.5	2S	17 600	0.69		126		
An-124-100M-150	408 000	45.8	5D	186 864	1.18	101	171	198.6	
An-148-100E	43 850	43.8	D	19 184	1.13	58			
An-158	43 850	44.3	D	19 404	1.13	58			
An-225	650 000	46.1	7D	299 650	1.23	101	171	198.6	





**PAVEMENTS**

34 GM-09

---

B707-320C	152 407	46.7	2D	71 174	1.24	88	142	167.1
B720B	106 594	46.4	2D	49 460	1.00	81	124	148.1



MAIN LEGS OF LANDING GEAR

Aircraft type	All-up mass (kg)	Load on one main gear leg (%)	Wheel arrangement	Load on each leg (kg)	Tire pressure (MPa)	Wheel spacing (cm)			Additional data for complex wheel arrangement
						(S)	(St)	(S <sub>D</sub> )	
B727-100	77 110	47.6	D	36 704	1.14	86			
B727-200 (Standard)	78 471	48.5	D	38 058	1.14	86			
B727-200 (Advanced)	95 254	46.5	D	44 293	1.19	86			
B737-100	50 349	45.9	D	23 110	1.08	77			
B737-200/200C	58 332	46.0	D	26 833	1.25	77			
B737-300	63 503	45.4	D	28 830	1.39	77			
B737-400	68 266	46.9	D	32 016	1.28	77			
B737-500	61 915	46.1	D	28 540	1.36	77			
B737-600	66 224	45.3	D	30 000	1.25	86			
B737-700	77 791	45.8	D	35 628	1.35	86			
B737-800	79 333	46.6	D	37 001	1.41	86			
B737-900	79 243	46.7	D	37 006	1.41	86			
B737-900ER	85 366	47.2	D	40 293	1.52	86			
B747-SP	318 875	21.9	2D/2D2	69 834	1.41	110	137	175.7	
B747-100/100B	341 555	23.1	2D/2D2	78 899	1.32	112	147	184.8	
B747-200B/300	379 204	22.7	2D/2D2	86 079	1.31	112	147	184.8	
B747-400/400ER	414 130	23.4	2D/2D2	96 906	1.57	112	147	184.8	
B747-8	449 056	23.7	2D/2D2	106 426	1.52	119	144	186.8	
B757-200	116 120	45.6	2D	52 951	1.26	86	114	142.8	
B757-300	124 058	46.4	2D	57 563	1.38	86	114	142.8	
B767-200/200ER	179 623	45.4	2D	81 549	1.31	114	142	182.1	
B767-300/300ER	187 334	46.2	2D	86 548	1.38	114	142	182.1	
B767-400ER	204 570	47.0	2D	96 148	1.47	116	137	179.5	
B777-200/200ER	298 464	45.9	3D	136 995	1.41	140	145	322.0	
B777-200LR	348 722	45.9	3D	160 063	1.50	140	145.3F 147R	324.0	





**PAVEMENTS**

34 GM-09

---

B777-300	300 278	47.4	3D	142 332	1.48	140	145	322.0
B777-300ER	352 442	46.2	3D	162 828	1.52	140	145.3F 147R	324.0



MAIN LEGS OF LANDING GEAR

Aircraft type	All-up mass (kg)	Load on one main gear leg (%)	Wheel arrangement	Load on each leg (kg)	Tire pressure (MPa)	Wheel spacing (cm)			Additional data for complex wheel arrangement
						(S)	(S <sub>i</sub> )	(S <sub>D</sub> )	
B787-8	228 383	45.6	2D	104 143	1.57	130	146	195.5	
B787-9	254 692	46.2	2D	117 772	1.56	152	151	214	
BAe146 Series 200	40 600	47.1	D	19 123	0.90	71			
CRJ-700	34 132	47.0	D	16 042	0.90	62			
CRJ-900/900 LR	38 555	46.3	D	17 851	1.15	62			
CRJ-1000	41 867	46.4	D	19 426	1.37	69			
Dash 8-400	29 347	47.0	D	13 793	1.57	50			
DC-9-32	49 442	46.2	D	22 842	1.07	64			
DC-9-51	55 338	47.0	D	26 009	1.19	66			
DC-10-10	207 745	46.7	2D	97 017	1.34	137	163	212.9	
DC-10-30	264 444	37.5	2D/D1	99 167	1.22	137	163	212.9	
E170	38 790	45.6	D	17 688	0.94	71			
E175	40 550	46.0	D	18 653	0.97	71			
E190	51 960	46.1	D	23 954	1.08	87			
E195	52 450	46.8	D	24 547	1.06	87			
Fokker 50	20 820	47.8	D	9 952	0.59	52			
Fokker 100	44 680	47.8	D	21 357	0.98	59			
IL-62M	168 000	47	2D	78 960	1.08	80	165	183.4	
IL-76TD-90BD	196 000	46.7	2Q	91 532	0.69	S1=82 S2=206			Quadruple wheels in each of two struts per each side. S1/S2 — distances between centres of contact areas of inner/outer wheels accordingly per each strut.
IL-96-400T	271 000	31.7	2D/2D1	85 907	1.23	110	140	178	Two dual wheels in tandem main gear/two dual wheels in tandem

MAIN LEGS OF LANDING GEAR

Aircraft type	All-up mass (kg)	Load on one main gear leg (%)	Wheel arrangement	Load on each leg (kg)	Tire pressure (MPa)	Wheel spacing (cm)			Additional data for complex wheel arrangement body gear.
						(S)	(Si)	(S <sub>D</sub> )	
L-100-30	70 670	48.4	2S	17 102	0.72			154	
L-1011-500	225 889	46.2	2D	104 361	1.27	132	178	221.6	
MD-11ER	287 124	38.8	2D/D1	111 404	1.42	137	163	212.9	
MD-83	73 028	47.4	D	34 615	1.34	71			
MD-87	63 956	47.4	D	30 315	1.17	71			
MD-90-30	76 430	47.0	D	35 922	1.33	71			
Tu-134A	49 000	47.1	2D	23 079	0.88	56	99	113.7	
Tu-154M	100 000	42.4	3D	42 400	0.98	62	F103 R98	210.3	
Tu -204CE	107 500	46.3	2D	49 719	1.37	80	127	150.1	
Tu -204-100C	110 750	46.3	2D	51 277	1.37	80	127	150.1	
Tu -214	110 750	46.3	2D	51 277	1.37	80	127	150.1	
Yak-42	57 500	47.0	2D	27 025	0.88	62.2	98	116	





**Appendix 2**  
**USER INFORMATION FOR THE**  
**ICAO-ACR COMPUTER PROGRAMME**

**1. GENERAL**

1.1 The ICAO-ACR computer programme is maintained by the FAA, William J. Hughes Technical Center (WJHTC). The programme implements the ACR computational procedures for rigid and flexible pavements. ICAO-ACR incorporates LEAF (Layered Elastic Computational Program for FAA Pavement Design and Evaluation Procedures — FAA), a computer programme that computes the structural responses of a layered pavement system according to Burmister's theory (layered elastic model). ICAO-ACR is distributed in compiled form as a Visual Basic.NET dynamiclink library (DLL). Programme files may be downloaded from the FAA WJHTC website: [Airport Pavement Software Programs — \(FAA\)](#).

1.2 The following files are available for download from the above website:

- a) ICAO-ACR is an executable (stand-alone) computer programme that executes the DLL *ACRClassLib.dll* programme, and returns standard ACR values.
- b) *ACRClassLib.dll* is a Visual Basic.NET DLL that can be linked directly to other programmes that either compute ACR directly, or that use the ACR computation to evaluate PCR. *ACRClassLib.dll* is not a stand-alone computer programme. Rather, it is intended to be run from within a separate calling programme such as the ICAO-ACR. Information on linking the library to a calling programme is given below.

1.3 ICAO-ACR is an open-source programme. The source codes for ICAO-ACR, *ACRClassLib.dll* and LEAF may be obtained from:

Federal Aviation Administration  
William H. Hughes Technical Center





Airport Technology R&D Branch., ANG-E26  
Atlantic City International Airport, NJ 08405  
United States

## 2. DYNAMIC-LINK LIBRARY (DLL) TECHNICAL INFORMATION

The DLL *ACRClassLib.dll* was compiled using Microsoft Visual Basic 2013 in the Microsoft Visual Studio programming environment. Its target framework is Microsoft.NET Framework 4.5.

2. 1 Input data. The *ACRClassLib.dll* class library accepts the following data inputs:

2.1. 1 Aircraft gross weight (in tons or pounds).

2.1. 2 Per cent of aircraft gross weight acting on the main gear, expressed as a decimal value.

2.1. 3 Number of wheels in the aircraft gear to be analysed.

2.1. 4 Tire pressure (in MPa or pounds per square inch).

2.1. 5 Horizontal coordinates (x, y) of each wheel (in millimetres or inches).

2.1. 6 For each wheel, a value 0 or 1, indicating whether the wheel is within the limits of the evaluation point grid. (The value 1 indicates that it is included.)

2.1. 7 Pavement type. This value can only be “Flexible” or “Rigid”.

2.1. 8 System of Units (metric or imperial).

2. 2 Output data. The *ACRClassLib.dll* class library returns the following data outputs, given the above inputs:

2.2. 1 ACR thickness, *t*, corresponding to four standard subgrade categories (in inches).

2.2. 2 ACR number corresponding to four standard subgrade categories.





2.3 Procedure for linking to DLL. *ACRClassLib.dll* is a .NET DLL. For projects compiled in the Microsoft Visual Studio.NET programming environment, the procedure for linking to the DLL is as follows:

2.3.1 In the project properties, add *ACRClassLib.dll* to References.

2.3.2 Declare all variables that will be passed between the calling programme and *ACRClassLib.dll*.

The following input variables are declared as Single type: aircraft gross weight, per cent gross weight, tire pressure, x-coordinate (array), y-coordinate (array). The following input variables are declared as Integer type: number of wheels, wheel selection variable (array) (see 2.1.6).

Certain variables have special definitions. The pavement type is specified as an enumerate variable type:

```
Public Enum PavementType
```

```
Flexible = 1
```

```
Rigid = 2
```

```
End Enum
```

ACR data are stored in a Visual Basic data structure ACR data:

```
Public Structure ACRdata
```

```
Dim libACR() As Single
```

```
Dim libACRthick() As Single
```

```
Dim libSubCat() As String
```

```
Dim libSubCatMPa() As String
```



## End Structure

The four elements in data structure ACR data are:

1. `ACRdata.libACR()` stores ACR numerical values following execution.
2. `ACRdata.libACRthick()` stores ACR thickness values following execution.
3. `ACRdata.libSubCat()` stores subgrade category letter designations.
4. `ACRdata.libSubCatMPa()` stores subgrade category standard modulus values in MPa.

Each of the elements 1 to 4 above is an array of length 5, of declared data type as indicated above. Within each array, the first element in the array `ACRData.array(0)` is not used, while the last four elements `ACRData.array(1)` through `ACRData.array(4)` correspond to standard subgrade categories “D” through “A” respectively. For reference, the following snippets of Visual Basic code are examples of function signatures used in the DLL. Executing the function `CalculateACR` from the calling programme returns ACR values in the array `ACRdata.libACR()`. The first function signature applies for the majority of gear types where all wheels in the main gear have equal tire pressure and load. The second function signature is used specifically to compute the flexible ACR for certain gear configurations (e.g. the Airbus A340 series) where the centre landing gear has a different tire pressure/wheel load combination than the wing landing gear.

Public Overloads Function `CalculateACR(ByVal PavementType As`

`clsACR.PavementType, _`

`ByVal gross_weight As Single, _`

`ByVal percent_gw As Single, _`

`ByVal wheels_number As Integer, _`





ByVal tire\_pressure As Single, \_

ByVal CoordX() As Single, \_

ByVal CoordY() As Single, \_

ByVal SW() As Integer, \_

ByVal Metric As Boolean) As ACRdata

Public Overloads Function CalculateACR(ByVal PavementType As

clsACR.PavementType, \_

ByVal gross\_weight As Single, \_

ByVal percent\_gw As Single, \_

ByVal wheels\_number As Integer, \_

ByVal tire\_pressure As Single, \_

ByVal CoordX() As Single, \_

ByVal CoordY() As Single, \_

ByVal percent\_gw2 As Single, \_

ByVal wheels\_number2 As Integer, \_

ByVal tire\_pressure2 As Single, \_

ByVal CoordX2() As Single, \_

ByVal CoordY2() As Single, \_





ByVal Metric As Boolean) As ACRCdata 'ACR for two gears

The following is sample Visual Basic code for declaring variables in the calling programme:

```
Dim ACRCData As ACRCClassLib.clsACR.ACRCdata
```

```
Dim PavementType As ACRCClassLib.clsACR.PavementType
```

```
Dim Gross_Wt, Percent_GW, Tire_Pressure As Single
```

```
Dim No_Wheels As Integer
```

```
Dim X1(), Y1() As Single
```

```
Dim SW() As Integer
```

```
Dim Metric As Boolean
```

2.3.3 Assign numerical values to declared input variables. The Boolean variable Metric is True for metric units, False for United States units. Figure A2-1 explains how to use variable SW(), which tells the programme whether to include a given wheel in the limits of the evaluation point grid (see 1.1.3.12). In ICAO-ACR, a value of 1 assigned to SW means the wheel is included in the strain evaluation point grid area; any value other than 1 is treated as 0. Note that *ACRCClassLib.dll* does not determine the correct number of wheels to include in the strain evaluation point grid. This determination should be made by the calling programme with reference to the guidance in 1.1.3.12). Also note that variable SW only controls which subgroup of wheels in the main gear assembly defines the strain evaluation point grid, not the number of wheels used to determine ACR. *ACRCClassLib.dll* determines the ACR value for all wheels passed to it (No\_Wheels). (In Figure A2-1, if all wheels 1-8 were assigned SW = 1, the difference in computed ACR values would be insignificant. However, the computation would take much longer.)





2.3.4 Call Function CalculateACR. The following snippet of Visual Basic code calls the function CalculateACR.

```
Dim RunACR As ACRCClassLib.clsACR
```

```
RunACR = New ACRCClassLib.clsACR()
```

```
ACRData = RunACR.CalculateACR(PavementType, Gross_Wt, Percent_GW,  
No_Wheels,
```

```
Tire_Pressure, X1, Y1, SW, Metric)
```

$$SW = \begin{cases} 1(\text{wheels } 1 - 4) \\ 0(\text{wheels } 5 - 8) \end{cases}$$

### 3. PROGRAMME ICAO-ACR

3.1 Programme ICAO-ACR functions as a stand-alone programme that computes flexible and rigid ACR values for arbitrary aircraft gear configurations, using the ACRCClassLib.dll DLL. For convenience, the programme includes a library of aircraft types commonly in use. For library aircraft, programme ICAO-ACR automatically selects the correct number of wheels for ACR evaluation, i.e. all wheels in the main landing assembly for flexible ACR and all wheels in the most demanding single truck for rigid ACR.



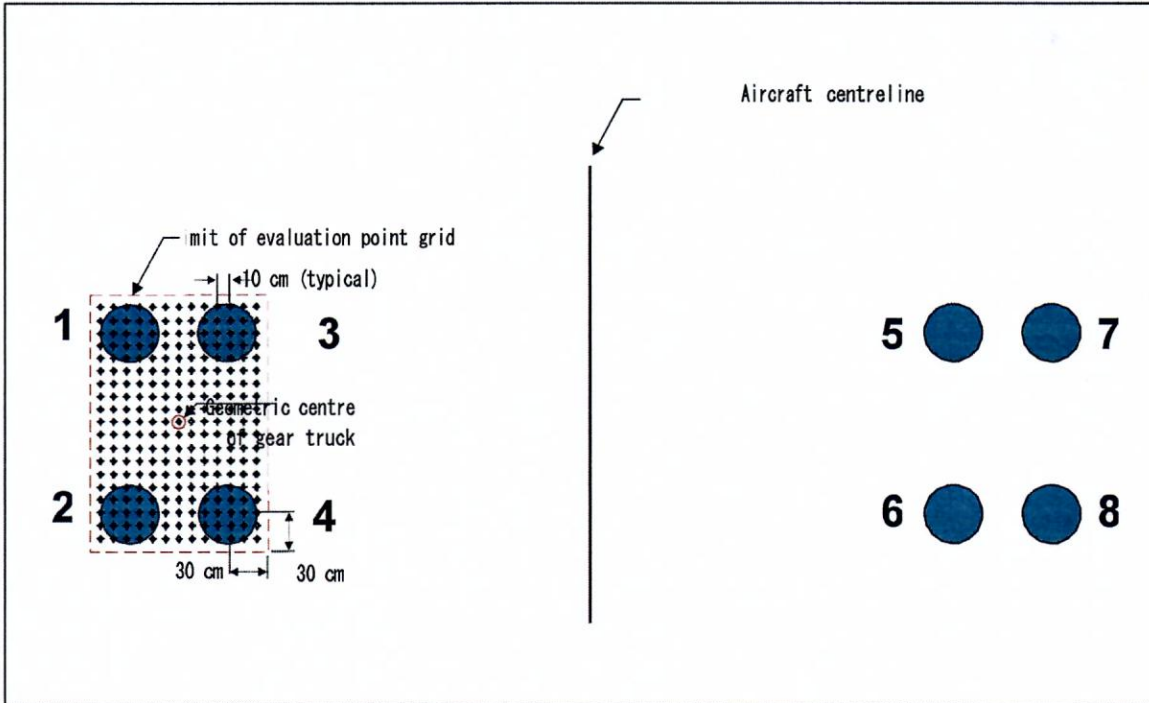

Figure A2-1. Explanation of Variable SW for 2D Aircraft Gear

### Appendix 3

#### DAMAGE MODEL FOR FLEXIBLE ACR

##### 1. ELEMENTARY DAMAGE LAW

1.1 The flexible ACR procedure relies on the subgrade failure criterion associated with the elementary damage law:

$$\log_{10}(C_e) = (-0.1638 + 185.19 \varepsilon)^{-0.60586}$$

where  $C_e$  is the number of traffic coverages producing subgrade failure, for a given subgrade vertical strain  $\varepsilon$ .

1.2 The elementary damage  $D_e$  is then defined as:

$$D_e(\varepsilon) = \frac{1}{C_e(\varepsilon)}$$

##### 2. MULTIPLE-AXLE GEAR LOADS

2.1 Modern landing gears often feature multi-axle wheel groups that produce complex strain profiles in the pavement, possibly with multiple strain peaks and no return to zero between peaks. As an example, Figure A3-1 describes the strain history profile for a pavement structure (i.e. the trace of all strain values along a longitudinal profile below the landing gear).

2.2 Due to the interaction between axles in tandem, the strain that makes the CDF equal to 1.0 for 36 500 passes of the evaluation aircraft will generally be different from that given by the above elementary damage law, which is based on the concept of load cycles. Therefore, the above equation cannot be used directly.

##### 3. CONTINUOUS INTEGRAL FORM OF THE DAMAGE LAW



3.1 In order to account for complex strain profiles induced by multiple-axle gear loads, the elementary damage law is extended to a continuous integral form thanks to Miner’s Rule and the Equivalent Single Peak (ESP) factor introduced by Jean Maurice Balay and Cyril Fabre (2009)

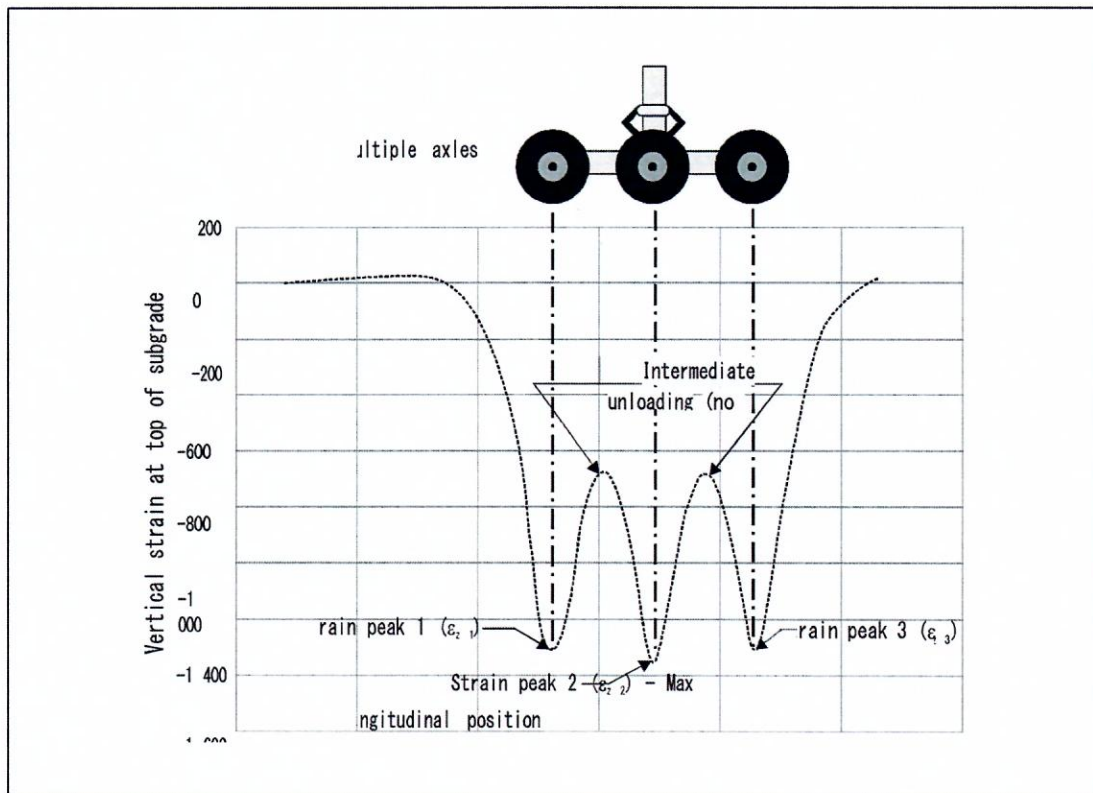

Figure A3-1.Example of multiple-axle gear strain response

3.2 The damage  $D_1$  for a single aircraft pass producing a longitudinal strain profile  $(x)$  is then calculated as:

$$D_1 = \int_{x=-\infty}^{x=+\infty} \left\langle \frac{dD_e(x)}{dx} \right\rangle dx = \int_{x=-\infty}^{x=+\infty} \frac{dD_e(\varepsilon)}{d\varepsilon} \left\langle \frac{d\varepsilon(x)}{dx} \right\rangle dx$$



where  $x$  refers to the longitudinal position along the strain profile and  $\langle z \rangle$  is the positive part of  $z$

$$\langle z \rangle = \begin{cases} 0, & z \leq 0 \\ z, & z > 0 \end{cases}$$

3.3 The longitudinal position  $x$  does not play an explicit role in this equation, therefore any other monotonically increasing parameterization (e.g. time) would lead to the same result.

3.4 For the specific case of a single-peak strain profile with maximum amplitude  $\epsilon_{max}$ ,  $D1$  reduces to the elementary damage law  $D1 = D_e(\epsilon_{max})$ . For an arbitrary strain profile, it is therefore possible to compute an equivalent single-peak strain  $\epsilon_{eq}$  that would produce the same damage as the entire profile:  $D1 = D_e(\epsilon_{eq})$ .

3.5 Based on this equivalence, the Equivalent Single Peak (ESP) ratio is then defined as the number of passes that would be required by a virtual aircraft producing a single-peak strain profile with maximum value  $\epsilon_{eq}$  to produce the same damage as one pass of a virtual aircraft producing a single-peak strain profile with maximum value  $\epsilon_{max}$ , as shown below.

*Note.— For a single-peak profile,  $\epsilon_{eq} = \epsilon_{max}$  and the ESP is 1.*

$$ESP = \frac{C_e(\epsilon_{eq})}{C_e(\epsilon_{max})} = \frac{D_e(\epsilon_{max})}{D_e(\epsilon_{eq})} \leq 1$$

3.6 The total damage  $D$  produced by  $N$  aircraft passes is now given by the following equation:

$$D = N \times D_e(\epsilon_{eq}) = N \times \frac{1}{ESP} \times D_e(\epsilon_{max}) = N \times \frac{1}{ESP} \times \frac{1}{C_e(\epsilon_{max})}$$



3. 7 If the longitudinal component of the Pass-to-Coverage (P/C) ratio is used, an equivalent expression of  $D$  is:

$$D = N \times \frac{1}{P/C} \times \frac{1}{C_e(\epsilon_{max})}$$

3. 8 ESP and P/C ratios are therefore functionally equivalent; they both represent the load repetition effect due to wheels in tandem in absence of lateral wander.

3. 9 Substituting the elementary damage law in  $D_1$ , the integral form can be expressed as:

$$D_1 = bc * \ln(10) \int_{x=-\infty}^{x=+\infty} [(a + b\epsilon)^{c-1} * 10^{(a+b\epsilon)^c}] < \frac{d\epsilon(x)}{dx} > dx$$

where  $a$ ,  $b$  and  $c$  are the parameters of the elementary damage law:

$$a = -0.1638$$

$$b = 185.19$$

$$c = -0.60586$$

3. 10 It can be verified that the above integral form is equivalent to:

$$D_1 = \sum_{k=1}^n s_k D_\epsilon(\epsilon_k)$$

where  $\epsilon_k$  are the strain extremums of the longitudinal profile and  $s_k$  is a factor characterizing the type of extremum:

$$s_k = \begin{cases} 1 & \text{if } \epsilon_k \text{ is a local maximum} \\ -1 & \text{if } \epsilon_k \text{ is a local minimum} \end{cases}$$



3.11 It should be noted that for the specific case of a single-peak strain profile with maximum value  $\epsilon_{max}$ , the integral form reduces to the elementary damage law  $D1 = De (\epsilon_{max})$ .

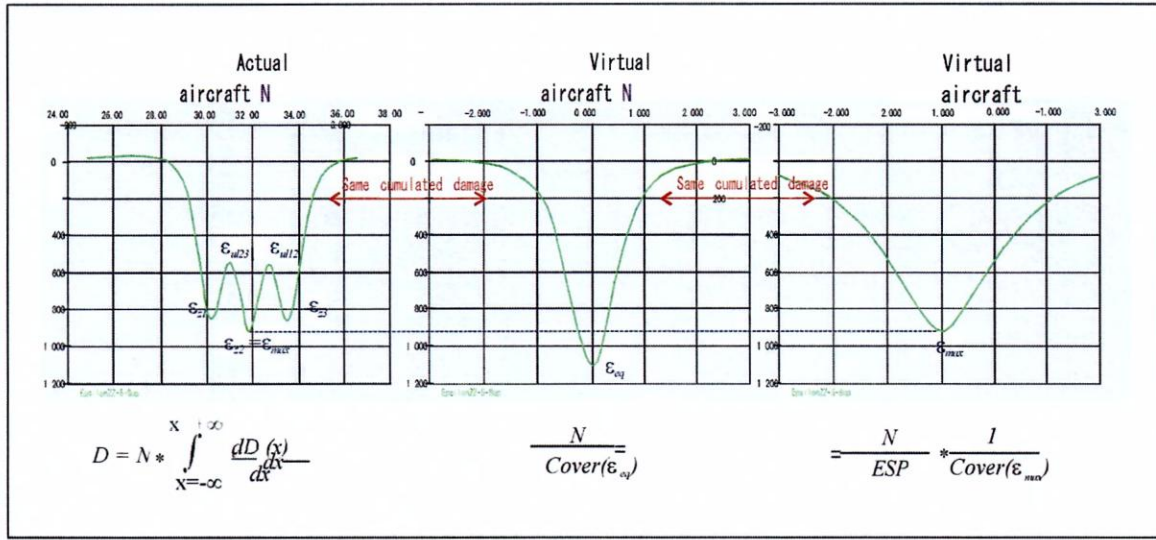

Figure A3-2. Relationship between  $\epsilon_{max}$ ,  $\epsilon_{eq}$  and ESP

#### 4. DAMAGE MODEL FOR FLEXIBLE ACR

4.1 The continuous integral form of the damage law is adopted for the computation of pavement damage in the flexible ACR procedure.

4.2 This procedure is implemented in the ICAO-ACR computer programme.





**Appendix 4**

**Page intentionally left blank**

---





**Appendix 5**

**Page intentionally left blank**



**Appendix 6****PAVEMENT OPERATIONS AND MAINTENANCE****RELATED GUIDANCE****1. PAVEMENT MANAGEMENT PROGRAMME (PMP)**

1.1 In JCAR PART 14, Chapter 10, a requirement for a maintenance programme has been established as a Standard, including preventive maintenance, making, by inference, the implementation of a pavement maintenance programme (PMP) mandatory.

1.2 Extending the pavement life through a regular programme, for a constantly changing aircraft fleet, requires more sophisticated maintenance techniques, such as a PMP. As preventive maintenance, it will be desirable to implement a PMP where appropriate, to maintain aerodrome pavements/facilities in a condition that does not impair the safety, regularity or efficiency of air navigation.

1.3 A PMP is a set of defined procedures for collecting, analysing, maintaining and reporting pavement data, to assist decision-makers in finding optimum strategies for maintaining pavements in safe serviceable condition over a given period of time for the least cost. A PMP should take into account:

- a) inspection procedures and condition assessment;
- b) maintenance protocols and procedures;
- c) management and oversight of completed works; and
- d) staff competence needed (human factors)

1.4 Depending on the complexity of the paved areas in an aerodrome, a PMP would contain as a minimum the following functionalities:

- a) pavement inventory (pavement condition evaluation, pavement history, traffic, costs); and



- b) pavement condition assessment (e.g. ASTM D5340-12 Standard Test Method for Airport Pavement Condition Index Surveys — PCI).

1.5 Additional functionalities could include:

- a) modelling to predict future conditions — analysis (serviceability rating, performance predictions, economic analyses-budgeting/programming);
- b) pavement performance report (past and future);
- c) pavement maintenance and repair (planning, scheduling, budgeting and analysing alternatives);  
and
- d) project planning.

## **2. METHODS FOR IMPROVING AND MAINTAINING RUNWAY SURFACE TEXTURE AND PAVEMENT MAGNETIC CHARACTERISTICS**

### **2.1 Purpose**

2.1.1 JCAR PART 14 requires that the surface of a paved runway be so constructed or resurfaced so as to provide surface friction characteristics at or above the minimum friction level set by CARC. Additional provisions include recommended specifications for the configuration of runway surfaces in terms of transverse and longitudinal slopes, surface evenness and texture. The purpose of this chapter is to provide guidance on proven methods for improving runway surface texture and drainage.

2.1.2 This chapter also identifies means to mitigate potentially hazardous magnetic field distortions induced by metallic masses in or below aerodrome pavements and magnetization of steel reinforcement meshes, tie-bars and dowels by the repeated use of magnetic devices to clean the surface of the pavement

### **2.2 Basic considerations**

*Historical background*

4.2. 1 One of the most significant and potentially dangerous operational issues during wet weather conditions is the aquaplaning phenomenon, which has been responsible for a number of aircraft incidents and accidents.

4.2. 2 Efforts to alleviate aquaplaning have resulted in the development of runway pavements with improved surface texture and drainage characteristics. Experience has shown that these types of pavements, apart from successfully minimizing aquaplaning risks, provide a substantially higher friction level in all degrees of wetness (i.e. from damp to flooded surfaces)

4.2. 3 The methods covered in this section for the enhancement of runway surface texture and drainage have been proven effective in improving the surface performance of runways.

*Functional requirements*

4.2. 4 A runway pavement, considered as a whole, is required to fulfil the following three basic functions, which is to:

- a) provide adequate bearing strength;
- b) provide good riding qualities; and
- c) provide good surface friction characteristics.

The first criterion in a) above, addresses the structure of the pavement, the second in b), the geometric shape of the top of the pavement and the third in c), the texture of the actual surface.

4.2. 5 All three criteria are considered essential to achieve a pavement that will functionally satisfy the operational requirements. From the operational aspect, however, providing good surface friction characteristics (third criterion) is considered the most important because it has a direct impact on the safety of aircraft operations. Regularity and efficiency may also be affected. Thus, the friction criterion may become a decisive factor for the selection and the form of the most suitable finish of the pavement surface.



4.2. 6 The attention of aerodrome pavement designers and managers is drawn to the trend-monitoring of surface friction characteristics contained in JCAR PART 14, Chapter 10. A trend-monitoring concept of the runway surface friction characteristics is shown in Figure A6-1.

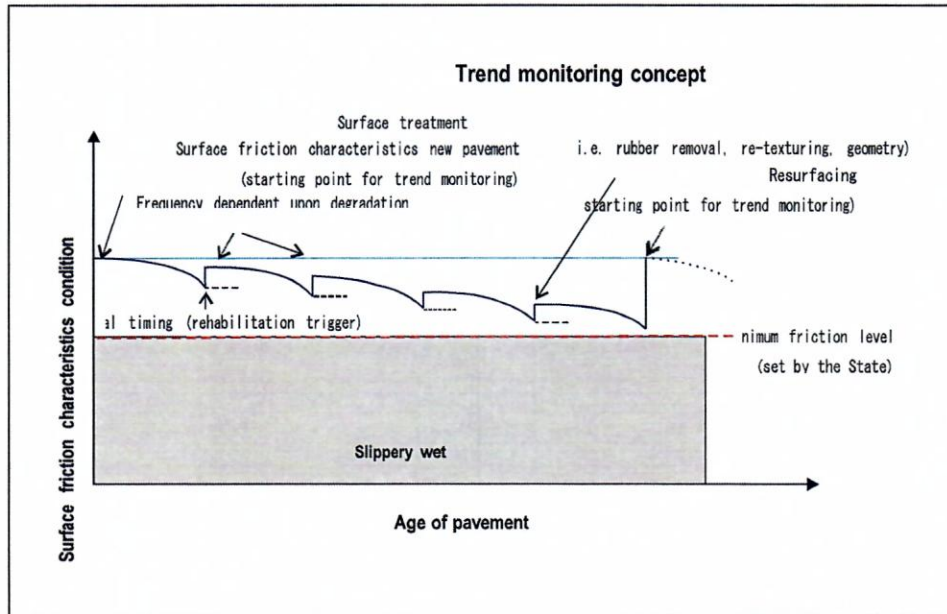

Figure A6-1. Trend monitoring concept

4.2. 7 The objective is to ensure that the surface friction characteristics for the entire runway remain at or above a minimum friction level specified by CARC

4.2. 8 The attention of aerodrome pavement designers and managers is drawn to the magnetic field distortions possibly induced by aerodrome pavements, which could interfere with aircraft navigation systems.

*Problem identification*

4.2. 9 When in a dry and clean state, individual runways generally provide comparable friction characteristics with operationally insignificant differences in friction levels, regardless of the type of





pavement (asphalt/cement concrete) and configuration of the surface. Moreover, the friction level available is relatively unaffected by the speed of the aircraft.

Hence, the operation on dry runway surfaces is satisfactorily consistent and no particular engineering criteria for surface friction are needed for this case.

4.2. 10 In contrast, when the runway surface is affected by water to any degree of wetness (i.e. from a damp to a flooded state), the situation is entirely different. For this condition, the friction levels provided by individual runways drop significantly from the dry value and there is considerable disparity in the resulting friction level between different surfaces.

This variance is due to differences in the type of pavement, the form of surface finish (texture) and the drainage characteristics (shape). Degradation of available friction, which is particularly evident when aircraft operate at high speeds, can have serious implications on safety, regularity or efficiency of operations. The extent will depend on the friction actually required versus the friction provided.

4.2. 11 The typical reduction of friction when a surface is wet and the reduction of friction as aircraft speed increases are explained by the combined effect of viscous and dynamic water pressures to which the tire/surface is subjected. This pressure causes a partial loss of “dry” contact, the extent of which tends to increase with speed. There are conditions where the loss is practically total and the friction drops to negligible values. This is identified as viscous, dynamic or rubber-reverted aquaplaning. The manner in which these phenomena affect different areas of the tire/surface interface and how they change in size with speed is illustrated in Figure A6-2.

*Painted areas on pavement surfaces*

4.2. 12 Painted areas on wet runway pavement surfaces can be very slippery. Additionally, aircraft with one main gear on a painted surface, and the other on an unpainted surface, may experience differential braking. It is important to keep the skid-resistant properties of painted surfaces to that of the surrounding non-painted surfaces. This usually involves adding a small amount of silica sand to the paint mix.





*Design objectives*

4.2. 13 In light of the foregoing considerations, the objectives for runway pavement design, which are similarly applicable for maintenance, can be formulated as follows:

A runway pavement should be so designed and maintained in order to provide a runway surface that meets adequately all functional requirements at all times throughout the anticipated lifetime of the pavement, in particular:

- a) to provide in all anticipated conditions of wetness, high friction levels and uniform friction characteristics; and
- b) to minimize the potential risk of all forms of aquaplaning (i.e. viscous, dynamic and rubber-reverted aquaplaning). Information on these types of aquaplaning is contained in Doc 9137, Part 2 —Pavement Surface Conditions.



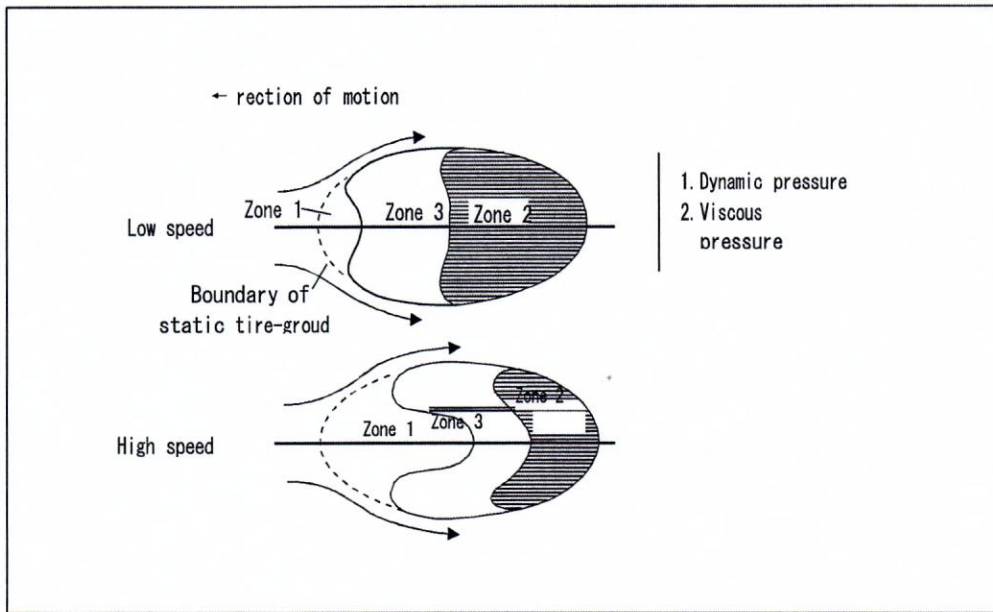

Figure A6-2.Areas of tire/surface interface

4.2. 14 The provision of adequate wet runway friction is closely related to the drainage characteristics of the runway surface. The drainage demand in turn is determined by local precipitation rates. Drainage demand, therefore, is a local variable that will essentially determine the engineering efforts and associated investments/costs required to achieve the objective. In general, the higher the drainage demand, the more stringent the interpretation and application of the relevant engineering criteria will become.

*Physical design criteria*

4.2. 15 The problem of friction on runway surfaces affected by water can be interpreted as a generalized drainage problem consisting of three distinct criteria:

- a) surface drainage (surface shape);





- b) tire/surface interface drainage (macrotexture); and
- c) penetration drainage (microtexture).

The three criteria can significantly be influenced by engineering measures and must all be satisfied to achieve adequate friction in all possible conditions of wetness (i.e. from a damp to a flooded surface).

*Surface drainage*

4.2. 16 Surface drainage is a basic requirement. It serves to minimize water depth on the surface, particularly in the area of the wheel path. The objective is to drain water off the runway in the shortest path possible and out of the area of the wheel path. Adequate surface drainage is provided primarily by an appropriately sloped surface (in both the longitudinal and transverse directions) and surface evenness. Drainage capability can, in addition, be enhanced by other measures such as providing closely spaced transverse grooves or by draining water initially through the voids of a specially treated wearing course (porous friction course). It should be clearly understood, however, that other measures (such as the provision of runway grooving) are not a substitute for poor runway shape, but is due to inadequate slopes or lack of surface evenness. This may be an important consideration when deciding on the most effective method for improving the surface performance of an existing runway.

*Tire/surface interface drainage (macrotexture)*

4.2. 17 The purpose of interface drainage (under a moving tire) is two-fold:

- a) to prevent, as far as feasible, residual surface bulk water from intruding into the forward area of the interface; and
- b) to drain intruding water to the outside of the interface

The objective is to achieve high-water discharge rates from under the tire with a minimum of dynamic pressure build-up. It has been established that this can be achieved by providing a surface with an open macrotexture.



4.2. 18 Interface drainage is actually a dynamic process highly correlated to the square of speed. Macrottexture is therefore particularly important for the provision of adequate friction in the high-speed range. From the operational aspect, this is most significant because it is in this speed range where lack of adequate friction is most critical with respect to stopping distance and directional control capability.

4.2. 19 In this context, it is worthwhile to make a comparison between the textures applied in road construction and runways. The smoother textures provided by road surfaces can achieve adequate drainage of the footprint of an automobile tire because of the patterned tire treads, which significantly contribute to interface drainage. Aircraft tires, however, cannot be produced with similar patterned treads and have only a number of circumferential grooves, which contribute substantially less to interface drainage. Their effectiveness diminishes relatively quickly with tire wear. The more vital factor, however, which dictates the macrottexture requirement, is the substantially higher speed range in which aircraft operate. This may explain why some conventional runway surfaces, which were built to specifications similar to road surfaces (relatively closed-textured), show a marked drop in wet friction with increasing speed and often a susceptibility to dynamic aquaplaning at comparatively small water depths.

4.2. 20 with cement concrete pavement surfaces, the provision of macrottexture may be achieved by using one of a number of available methods to apply macrottexture characteristics to the surface during the finishing process, such as brush or broom finish or burlap drag finish. With asphalt surfaces, the provision of macrottexture may be achieved by the selection of the appropriate aggregate (in terms of size, gradation, resistance to polish and wear, and shape) or by providing open-graded surfaces.

4.2. 21 A further design criteria calls for best possible uniformity of surface texture. This requirement is important to avoid undue fluctuations in available friction, since these fluctuations would degrade anti-skid braking efficiency or may cause tire damage.

4.2. 22 Methods which enhance macrottexture and/or are effective in reducing the risk of aquaplaning are described in 2.3.

*Penetration drainage (microtexture)*

4.2. 23 The purpose of penetration drainage is to establish “dry” contact between the asperities of the surface and the tire tread in the presence of a thin viscous water film. The viscous pressures that increase with speed tend to prevent direct contact, except at those locations of the surface where asperities prevail, penetrating the viscous film. This kind of roughness is defined as microtexture.

4.2. 24 Microtexture refers to the fine-scale roughness of the individual aggregate of the surface and is hardly detectable by the eye, however, assessable by the touch. Accordingly, adequate microtexture can be provided by the appropriate selection of aggregates known to have a harsh surface. This excludes in particular all polishable aggregates.

4.2. 25 Macrottexture and microtexture are both vital components for wet surface friction (i.e. both must adequately be provided to achieve acceptable friction characteristics in all different conditions of wetness). The combined effect of microtexture and macrottexture of a surface on the resulting wet friction versus speed is illustrated in Figure A6-3 indicating also that the design objective formulated in 2.2.14 can be achieved by engineering means.



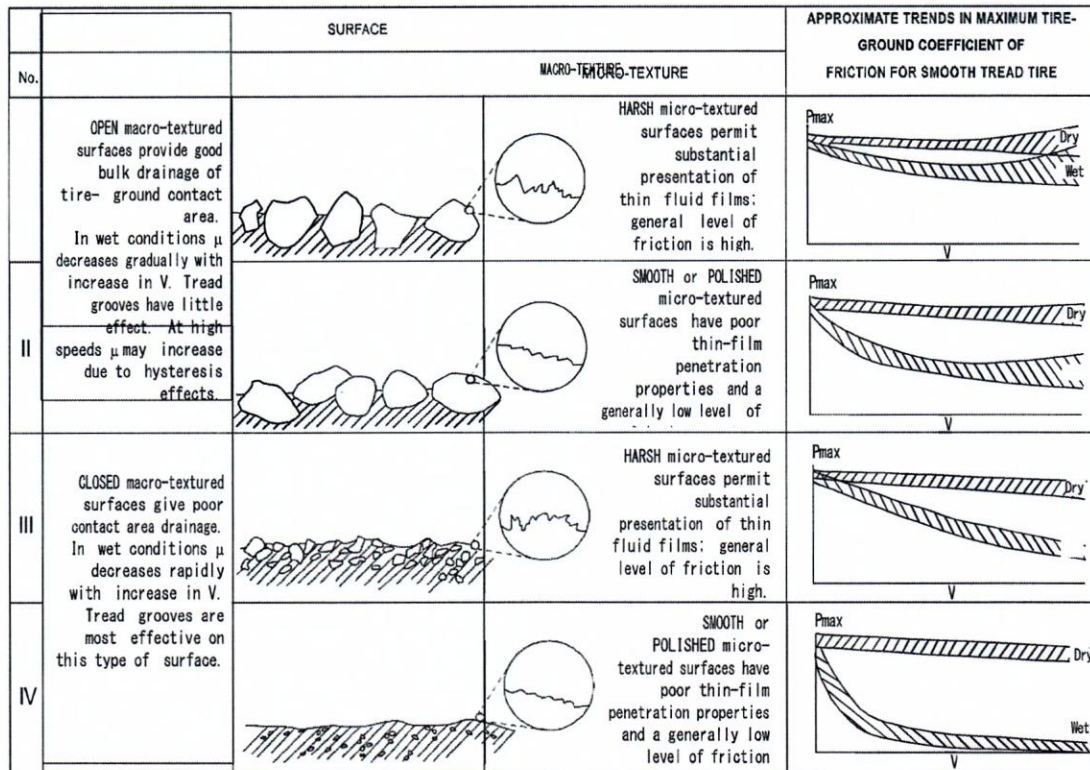

Figure A6-3. Effect of surface texture on tire-surface coefficient of friction

4.2. 26 A major problem with microtexture is that it can change within short time periods (unlike macrotexture), without being easily detected. A typical example of this is the accumulation of rubber deposits in the touchdown area, which will largely mask microtexture without necessarily reducing macrotexture. The result can be a considerable decrease in the wet friction level. This problem is addressed by periodic friction measurements, which provide a measure of existing microtexture. If it is determined that low wet friction is caused by degraded surface microtexture, there are methods available to effectively restore adequate microtexture for existing runway surfaces (see 2.3).

*Minimum specifications*



4.2. 27 The basic engineering specifications for the geometrical shape (longitudinal slope/transverse slope/surface evenness) and for the texture (macrotexture) of a runway surface are contained in JCAR PART 14.

#### *Slopes*

4.2. 28 All new runways should be designed with uniform transverse profile in accordance with the value of transverse slope recommended in JCAR PART 14, and with a longitudinal profile as nearly level as possible. A cambered transverse section from a centre crown is preferable, but if for any reason this cannot be provided, then the single runway crossfall should be carefully related to prevailing wet winds to ensure that surface water drainage is not impeded by the wind blowing up the transverse slope (in the case of single crossfalls, it may be necessary at certain sites to provide cut-off drainage along the higher edge to prevent water from the shoulder spilling over the runway surface). Particular attention should be paid to the need for good drainage in the touchdown zone since aquaplaning induced at this early stage of the landing, once started, can be sustained by considerably shallower water deposits further along the runway.

4.2. 29 If these ideal shape criteria are met, aquaplaning incidents will be reduced to a minimum, but departures from these ideals will result in an increase of aquaplaning probability, no matter how good the friction characteristic of the runway surface may be. These comments hold true for major reconstruction projects and, in addition, when old runways become due for resurfacing, the opportunity should be taken, wherever possible, to improve the levels to assist surface drainage. Every improvement in shape helps, no matter how small.

#### *Surface evenness*

4.2. 30 This is a constituent of runway shape which requires equally careful attention. Surface evenness is also important for the riding quality of high-speed jet aircraft.

4.2. 31 Requirements for surface evenness are described in JCAR PART 14, Attachment A, Section 5, and reflect good engineering practices. Failure to meet these minimum requirements can seriously



degrade surface water drainage and lead to ponding. This can be the case with aging runways as a result of differential settlement and permanent deformation of the pavement surface. Evenness requirements apply not only for the construction of a new pavement but throughout the life of the pavement. The maximum tolerable deformation of the surface should be specified as a vital design criterion. This may have a significant impact on the determination of the most appropriate type of construction and type of pavement.

4.2. 32 With respect to susceptibility to ponding when surface irregularities develop, runway shapes with maximum permissible transverse slopes are considerably less affected than those with marginal transverse slopes. Runways exhibiting ponding will normally require a resurfacing and reshaping to effectively alleviate the problem.

*Surface texture*

4.2. 33 Surface macrotexture requirements are specified in JCAR PART 14, in terms of average surface texture depth, which should not be less than 1 mm for new surfaces. The minimum value for average texture depth has been empirically derived and reflects the absolute minimum required to provide adequate interface drainage. Higher values of average texture depth may be required where rainfall rates and intensities are a critical factor to satisfy interface drainage demand. Surfaces which fall short of the minimum requirement for average surface texture depth will show poor wet friction characteristics, particularly if the runway is used by aircraft with high landing speeds. Remedial action is, therefore, imperative. Methods for improving the surface performance of runways are described in 2.3.

4.2. 34 As outlined earlier, uniformity of the texture is also an important criterion. In this respect, there are several specific types of surfaces which meet this requirement (see 2.3). These surfaces will normally achieve average texture depths higher than 1 mm.

4.2. 35 The macrotexture of a surface does not normally change considerably with time, except for the touchdown area as a result of rubber deposits. Therefore, periodic control of available average surface texture depth on the uncontaminated portion of the runway surface will only be required at long intervals.



4.2. 36 With respect to microtexture there is no direct measure available to define the required fine scale roughness of the individual aggregate in engineering terms. Accordingly, there are no relevant specifications in JCAR PART 14. However, from experience it is known that good aggregate must have a harsh surface and sharp edges to provide good water film penetration properties. It is also important that the aggregate be actually exposed to the surface and not coated entirely by a smooth material. Since microtexture is a vital component of wet friction regardless of speed, the adequacy of microtexture provided by a particular surface can be assessed generally by friction measurements. Lack of microtexture will result in a considerable drop in friction levels throughout the whole speed range.

This will occur even with minor degrees of surface wetness (e.g. damp). This rather qualitative method may be adequate for detecting lack of microtexture in obvious cases.

4.2. 37 Degradation of microtexture caused by traffic and weathering may occur, in contrast to macrotexture, within comparatively short time periods and can also change with the operational state of the surface. Accordingly, shorterterm periodic checks by friction measurements are necessary, in particular with respect to the touchdown areas where rubber deposits quickly mask microtexture.

#### *Runway surface friction measurement*

JCAR part 14, requires runway surfaces to be measured periodically with a continuous friction measuring device using self-wetting features to verify their friction characteristics when wet. These friction characteristics must not fall below minimum levels specified by CARC. Table 3-1 of CARC 34 GM-08 shows the criteria in use in some States for specifying the friction characteristics of new or resurfaced runway surfaces, for establishing maintenance planning levels and for setting minimum friction levels.

4.2. 38 For the design of a new runway, the optimum application of the basic engineering criteria for runway shape and texture will normally provide a fair guarantee of achieving levels well in excess of the applicable specified minimum wet friction level. When large deviations from the basic specifications





for shape or texture are planned, it will then be advisable to conduct wet friction measurements on different test surfaces in order to assess the relative influence of each parameter on wet friction, prior to deciding on the final design. Similar considerations apply for surface texture treatment of existing runways.

**2.3 Improvement of surface performance of runways**

2.3.1 The methods described in this section are based on the experiences of several States. It is important that a full engineering evaluation of the existing pavement be made at each site before any particular method is considered, and that, once selected, the method is suitable for the types of aircraft operating. It should be noted that repairs or resurfacing of the pavement may be required in certain cases prior to the application of the improvement method in order for it to be effective.

*Grooving of pavements*

2.3.2 There are no operational objections to the grooving of existing surfaces. Experience of operating all types of aircraft from grooved surfaces over a number of years indicates that there is no limit within the foreseeable future to the aircraft size, loading or type for which such surfaces will be satisfactory. There is inconclusive evidence of a slightly greater rate of tire wear under some operational conditions.

2.3.3 Methods of grooving include the sawing of grooves in existing or properly cured asphalt, shown in Figure A6-4 or PCC pavements, and the grooving or wire combing of PCC while it is in the plastic condition. Based on current techniques, sawed grooves provide a more uniform width, depth, and alignment. This method is the most effective means of removing water from the pavement/tire interface. However, plastic grooving and wire combing are also effective in enhancing pavement surface drainage. They are cheaper to construct than the sawed grooves, particularly where very hard aggregates are used in pavements. Therefore the cost-benefit relationship should be considered in deciding which grooving technique should be used for a particular runway.





Figure A6-4. Grooving of asphalt surface (scale shows 2.5 cm divisions)

2.3. 4 The following factors should be considered in determining the need for runway grooving:

- a) historical review of aircraft accidents/incidents related to aquaplaning at airport facility;
- b) wetness frequency (review of annual rainfall rate and intensity);
- c) transverse and longitudinal slopes, flat areas, depressions, mounds or any other abnormalities that may affect water run-off;
- d) surface texture quality as to slipperiness under dry or wet conditions. Polishing of aggregate, improper seal coating, inadequate microtexture/macrotecture and contaminant build-up are some examples of conditions which may affect the loss of surface friction;
- e) terrain limitations such as drop-offs at the ends of runway end safety areas;
- f) adequacy of number and length of available runways;



- g) cross-wind effects, particularly when low friction factors prevail; and
- h) the strength and condition of existing runway pavements.

*Evaluation of existing pavement*

2.3. 5 Asphalt surfaces must be examined to determine that the existing wearing course is dense, stable and well-compacted. If the surface exhibits ravelling or where large particle fractions of coarse aggregate are exposed on the surface itself, then other methods will need to be considered or resurfacing will have to be undertaken before grooving is conducted. Rigid pavement must be examined to ensure that the existing surface is sound, free of scaling or extensive spalls, or “working cracks”. Apart from the condition of the surface itself, the ratio between transverse and longitudinal slopes becomes important. If the longitudinal slopes are such that the water run-off is directed along the runway instead of clearing quickly to the runway side drains, then a condition could arise when the grooves would fill with free water, fail to drain quickly and possibly encourage aquaplaning. For the same reason, surfaces with depressed areas should be repaired or replaced before grooving.

*Effectiveness of treatment*

2.3. 6 Transverse grooving improves the macrotexture of the runway pavement surface, reduces water film thicknesses during rainfall and provides an escape channel for water that may become trapped between the pavement surface and an aircraft tire. These effects reduce the potential for aircraft aquaplaning under wet conditions. Grooving may also improve aircraft braking performance on a wet runway as compared to a wet non-grooved runway. Grooving does however have limits with respect to coping with deep standing water due to heavy rainfall. In addition, the build-up of rubber deposits in the grooves will reduce the effectiveness of the grooving, and rubber removal should be performed as necessary. The improvement related to grooving applies to both asphalt and concrete pavement surfaces. For asphalt pavements, the duration of this improvement will depend on the properties of the asphalt wearing course, climate and traffic.

*Technique*



2.3. 7 The surface is to be grooved across the runway at right angles to the runway edges or parallel to non-perpendicular transverse joints, where applicable, with grooves which follow across the runway in a continuous line without break. The machine for grooving will be equipped with diamond-saw cutting blades capable of cutting 0.5 m width of multiple parallel grooves in one pass, as shown in Figure A6-5. Sawing machines include water tanks and pressure sprays. Commonly used groove configuration is 6 mm by 6 mm with a centre spacing of 38 mm.



Figure A6-5. Grooving with saws

2.3. 8 The grooves may be terminated within 3 m of the runway pavement edge to allow adequate space for the operation of the grooving equipment. Tolerances should be established to define groove alignment, depth, width and spacing. Suggested tolerances are  $\pm 40$  mm in alignment for 22 m, and average depth or width  $\pm 1.5$  mm. Grooves should not be cut closer than 75 mm to transverse joints. Diagonal or longitudinal saw kerfs where lighting cables are installed should be avoided. Grooves may be continued through longitudinal construction joints. Extreme care must be exercised when grooving near in-runway lighting fixtures and subsurface wiring. A 60 cm easement on each side of the light fixture is recommended to avoid contact by the grooving machine. Contracts should specify the contractor's liability for damage to light fixtures and cable. Clean-up is extremely important and should be continuous throughout the grooving operation. The waste material collected during the grooving



operation must be disposed of by flushing with water, sweeping or vacuuming. If waste material is flushed, the specifications should state whether the airport owner or contractor is responsible for furnishing water for clean-up operations. Waste material collected during the grooving operation must not be allowed to enter the airport storm or sanitary sewer, as the material will eventually clog the system. Failure to remove the material can create conditions that will be hazardous to aircraft operations.

*Groove deterioration*

2.3. 9 Periodic inspections of the grooves by the airport operator should be conducted to measure the depth and width to check for wear and damage. When 40 per cent of the grooves in the runway are less than a half their design depth (either 1.5 or 3 mm) and or width for a distance of 500 m, the grooves effectiveness for preventing aquaplaning has been reduced and corrective action to reinstate the 3 mm or 6 mm groove depth is recommended. Re-grooving of a worn asphalt pavement may not be feasible without causing an FOD risk; it may be necessary to resurface and groove full width.

*Plastic grooves and wire comb*

2.3. 10 Grooves can be constructed in new PCC pavements while in the plastic condition. The “plastic grooving” or wire comb, as depicted in Figure A6-6, technique can be included as an integral part of the paving train operation. A test section should be constructed to demonstrate the performance of the plastic grooving or wire combing equipment and set a standard for acceptance of the complete product.





Figure A6-6. New concrete surfacing textured with wire comb

### *Technique*

2.3. 11 Tolerances for plastic grooving should be established to define groove alignment, depth, width and spacing. Suggested tolerances are:

- a)  $\pm 7.5$  mm in alignment for 22 m;
- b) minimum depth 3 mm, maximum depth 9.5 mm;
- c) minimum width 3 mm, maximum width 9.5 mm; and
- d) minimum spacing 28 mm, maximum spacing 50 mm centre to centre.

Tolerances for wire combing should result in an average 3 mm x 3 mm x 12 mm configuration

2.3. 12 The junction of groove face and pavement surface should be squared or rounded or slightly chamfered. Hand-finishing tools, shaped to match the grooved surface, should be provided. The contractor should furnish a “bridge” for workmen to work from to repair any imperfect areas. The

equipment should be designed and constructed so that it can be controlled to grade and be capable of producing the finish required. If pavement grinding is used to meet specified surface tolerances, it should be accomplished in a direction parallel to the formed grooves.

#### *Grooving runway intersections*

2.3. 13 Runway intersections require a decision as to which runway's continuous grooving is to be applied. The selection of the preferred runway will normally be dictated by surface drainage aspects, except that if this criterion does not favour either runway, consideration will be given to other relevant criteria.

#### *Criteria*

2.3. 14 The main physical criterion is surface drainage. Where drainage characteristics are similar for the grooving pattern of either runway, consideration should be given to the following operational criteria:

- a) aircraft ground speed regime;
- b) touchdown area; and
- c) risk assessment.

#### *Surface drainage*

2.3. 15 The primary purpose of grooving a runway surface is to enhance surface drainage. Hence, the preferred runway is the one on which grooves are aligned closest to the direction of the major downslope within the intersection area. The major downslope can be determined from a grade contour map.

2.3. 16 The above aspect is essential because intersection areas involve, by design, rather flat grades (to satisfy the requirement to provide smooth transition to aircraft travelling at high speeds) and, therefore, are susceptible to water ponding.





2.3. 17 Where appropriate, consideration may be given to additional drainage channels across the secondary runway where the groove pattern terminates in order to prevent water from this origin from affecting the intersection area.

*Aircraft speed*

2.3. 18 Since grooving is particularly effective in the high ground-speed regime, preference should be given to that runway on which the higher ground speeds are frequently attained at the intersection.

*Touchdown area*

2.3. 19 Provided the speed criterion does not apply, the runway on which the intersection forms part of the touchdown area should be preferred because grooving will provide rapid wheel spin-up on touchdown in particular when the surface is wet.

*Risk assessments*

2.3. 20 Eventually, the selection of the primary runway can be based on an operational judgment of risks for overruns (rejected take-off or landing) taking into account:

- a) runway use (take off/landing);
- b) runway lengths;
- c) available runway end safety areas;
- d) movement rates; and
- e) particular operating conditions.



*Diamond grinding of cement concrete*

2.3. 21 There do not appear to be any operational objections to the diamond grinding of existing PCC surfaces, see Figure A6-7, and this method of treatment seems to be suitable for all types of aircraft.



Figure A6-7. Existing Portland cement concrete (PCC) before and after grinding  
*Consideration of existing pavement*

2.3. 22 It would be difficult to grind uniformly concrete surfaces which are “rough”. Pavements with damaged or poorly formed joints, or on which laitance has led to extensive spalling of the surface, would be equally difficult to grind.

If the existing surface is reasonably free of these defects, there are no other engineering limitations to grinding.



*Effectiveness of treatment*

2.3. 23 Transverse grinding of concrete considerably improves the friction characteristics of pavements initially textured at the time of construction with burlap or brooms. The useful life of the treatment depends on the frequency of traffic but in general the grinding remains effective for the life of the concrete.

*Runway ends*

2.3. 24 Grinding should not be performed on the runway ends to make it easier to wash down and clean off fuel and oil droppings. Moreover, engine blast can be more damaging on a surface on which grinding has been performed than on an untextured surface. The directional control of an aircraft moving from the taxiway on to the runway can become reduced, presumably because of a tendency of the tires to track in the transverse texture of the runway. In addition, a possibility of an increase in tire wear in turning cannot be totally discounted.

*Technique*

2.3. 25 An acceptable “trial” area should be available for inspection and it is recommended that this be provided at the aerodrome to determine a precise texture depth requirement, as this will tend to vary with the quality of the concrete.

Grinding is to be performed transversely by a single pass of a cutting drum, as shown in Figure A6-8, incorporating not less than 50 circular segmented diamond saw blades per 30 cm width of drum. The drum is to be set at 3 mm setting on a multi-wheeled articulated frame with outrigger wheels, fixed to give a uniform depth of grinding over the entire surface of the runway to ensure the removal of all laitance and the exposure of the aggregate. It should be noted that grinding generates a great deal of dust during treatment and it is necessary to sweep and wash down the surface before operations restart.

*Porous friction course*

2.3. 26 The porous friction course consists of an open-graded, bituminous surface course composed of mineral aggregate and bituminous material, mixed in a central mixing plant, and placed on a prepared surface, as shown in Figure A6-9. This friction course is deliberately designed not only to improve the skid-resistance, but to reduce aquaplaning incidences by providing a “honeycomb” material to ensure quick drainage of water from the pavement surface direct to the underlying impervious asphalt. The porous friction course is able to maintain, over a long period, a constant and relatively high wet friction value due to its porosity and durability.



figure A6-8.Diamond grinding of cement concrete



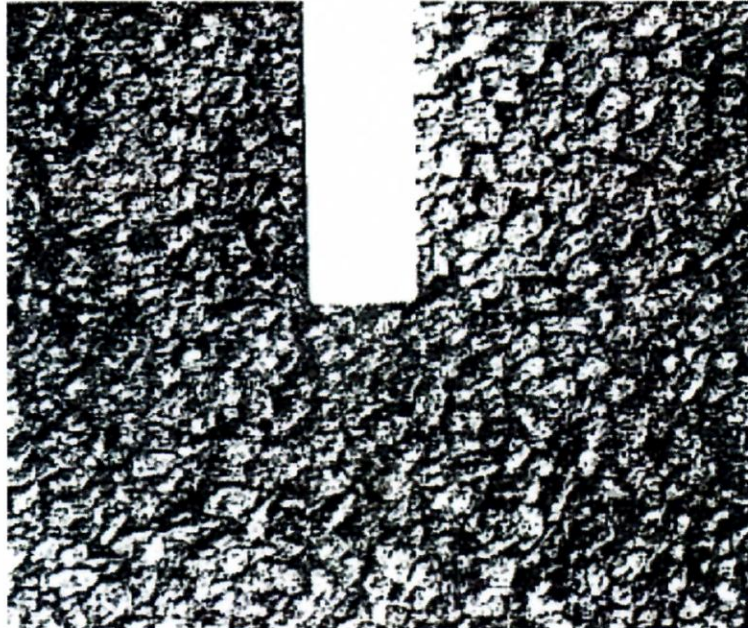

Figure A6-9.Porous friction course surfacing

*Limitations of porous friction course*

2.3. 27 Friction courses of this kind should only be laid on new runways of good shape or on reshaped runways approaching the criteria expected for new runways. They must always be over densely graded impervious asphalt wearing courses of high level of stability. Both of these requirements are necessary to ensure a quick flow of the water below the friction course and over the impervious asphalt to the runway drainage channels. In addition, special consideration has to be given to periodic cleaning of the surface to maintain its porosity and care needs to be taken during snow and ice removal not to damage the surface.

*Runway ends*

2.3. 28 The porous friction course is not recommended at the runway ends. Oil and fuel droppings would clog the interstices and soften the bitumen binder and jet engine heat would soften the material which blast would then erode.

Erosion would tend to be deeper than on normal dense asphalt and the possibility of engine damage through ingestion of particles of runway material should not be discounted. Scuffing might occur in turning movements during the first few weeks after laying. For these reasons, it is recommended that runway ends be constructed of brushed or grooved concrete, or of dense asphalt.

*Aggregate*

2.3. 29 The aggregate consists of crushed stone, crushed gravel or crushed slag, with or without other inert finely divided mineral aggregate. The aggregate is composed of clean, sound, tough, durable particles, free from clay balls, organic matter and other deleterious substances. The type and grade of bituminous material is to be based on geographical location and climatic conditions. The maximum mixing temperature and controlling specification is also to be specified.

*Weather and seasonal limitations*

2.3. 30 The porous friction course is to be constructed only on a dry surface when the atmospheric temperature is 10 °C and rising (at calm wind conditions) and when the weather is not foggy or rainy.

*Preparation of existing surfaces*

2.3. 31 Rehabilitation of an existing pavement for the placement of a porous friction course includes construction of bituminous overlay, joint sealing, crack repair, reconstruction of failed pavement and cleaning of grease, oil, and fuel spills. Immediately before placing the tack-coat, it is critical that the underlying course is cleared of all loose or deleterious material and cleaned with power blowers, power brooms or hand brooms as directed. A tack-coat is to be placed on those existing surfaces where a tack-coat is necessary for bonding the porous friction course to the existing surface. If emulsified asphalt is





used, placement of the porous friction course can be applied immediately. However, if cutback asphalt is used, placement of the porous friction course must be delayed until the tack-coat has properly aired.

## 2.4 State practices

2.4.1 Practice of France — bituminous concrete (Béton Bitumineux pour Chaussées Aéronautiques (BBA)) for surface course

2.4.1.1 Wet runway surface friction can be obtained from an adequate combination of macrotexture and microtexture. Crushing aggregates or specific highly polished stone value (PSV) aggregates are effective ways of providing and maintaining high microtexture. High runway surface macrotexture can be obtained from an appropriate choice of aggregate gradation and mortar mix. European standards define the composition, performance characteristics and test conditions for skid resistant bituminous products and mixtures (i.e. NF EN 13 108-1).

2.4.1.2 Standard NF EN 13 108-1 describes eight types of materials that can be used as aerodrome pavement surface courses. Four of these, designated as béton bitumineux aéronautique (BBA), have proven high surface characteristics. BBA can be continuous or discontinuous grading, each grade with 0/10 mm and 0/14 mm aggregate sizes and can be used as surface courses in new construction and overlay. Figure A6-10 shows a typical surface texture of ungrooved discontinuous graded BBA 0/14.





Figure A6-10. BBA 0/14 surface texture

2.4.1.3 BBA 0/14 achieves mean texture depth (MTD) specifications for runways and rapid exit taxiways. For any other aerodrome pavement surfacing, BBA 0/10 is also suitable. The surface characteristics inherent to these products may negate the operational need for special treatment, such as grooving (without qualifying for specific credit for aircraft performance). They are therefore ready for trafficking as soon as the material cools down to ambient temperature. BBA runways are easier to maintain compared to grooved asphalt runways.

2.4.1.4 BBA is an effective way of meeting the requirements regarding friction and texture values as constructed, without any supplementary surface treatment. Moreover, the friction tends to increase during the first year of service due to the wear of excess asphalt binder by traffic. It is less prone to rubber build-up than grooved materials. Nevertheless, BBA retains moisture for a longer period than grooved runways. In winter conditions, it means de-icing agents may have to be applied on a more frequent basis during periods of cold, damp weather.

2.4.2 Practice of China — stone matrix asphalt (SMA) for surface course



2.4.2. 1 The main features of a stone matrix asphalt, also called stone mastic asphalt (SMA), the wearing course is its rough surface and large texture depth. The texture depth of an SMA-16 surface course is not less than 1.2 mm and SMA-13 is not less than 1.0 mm. The skid resistance of an SMA wearing course is better than a conventional surface course and is suitable for paving of a new construction wearing course or wearing course overlaid on existing pavement.

In 1996, the runway 18L/36R at Beijing Capital International Airport was the first major airport pavement to be overlaid with SMA on deteriorated concrete. Given the benefits and practicality of this surface course, almost all asphalt runways used SMA pavement in China, in addition to other countries, such as the United Kingdom, France, Germany, Norway and Singapore. Figure A6-11 shows an SMA wearing course.



Figure A6-11. SMA wearing course

2.4.2. 2 SMA is differentiated from dense-graded mixes by its coarse aggregate skeleton, consisting of a limited number of particle sizes, which carries the load. Mastic, consisting of mineral filler, fibres and asphalt binder, fills the voids between the coarse aggregate skeleton. In addition to good skid resistance, SMA pavement also has the following

2.4.2. 3



advantages:

- a) its high coarse aggregate content interlocks to form a stone skeleton that resists permanent
- b) deformation and fuel spillage, which is able to adapt to the needs of heavy traffic;
- c) its improved pavement performance includes low-temperature crack resistance, anti-aging capability,
- d) water damage resistance and durability, due to its fibrous characteristics, higher bitumen content, thicker bitumen film and lower air voids; and
- e) higher content of mineral filler enhances the bonding capability between bitumen and aggregate.

2.4.2. 4 Figure A6-12 presents the different composition of dense graded asphalt concrete (conventional asphalt), SMA and porous asphalt (open graded friction course). Table A6-1 presents comparative performance results of the three surfaces.

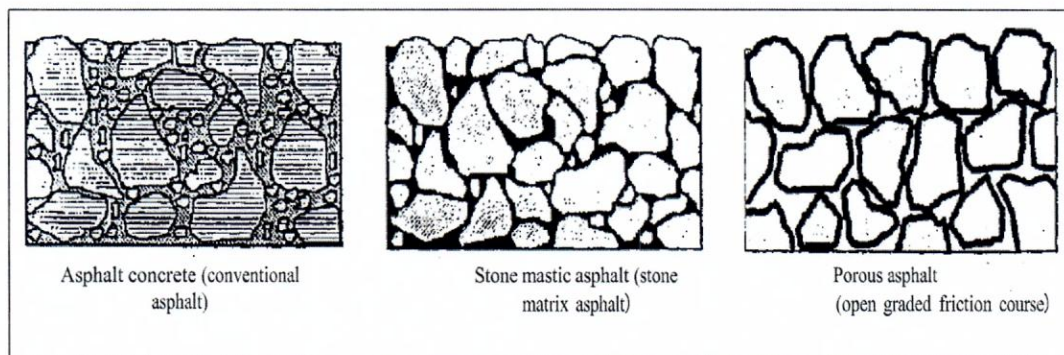

Figure A6-12. Asphalt concrete versus SMA versus porous asphalt





table A6-1 Performance comparative results

<i>Structure type</i>	<i>Dense graded asphalt concrete</i>	<i>Stone mastic asphalt (SMA)</i>	<i>Open graded friction course</i>
Texture depth	0	+	+
Noise resistance	0	+	++
Fatigue resistance	0	0	0
Deformation resistance	0	++	++
Reflection crack resistance	0	+	--
Low temperature crack resistance	0	+	--
Stripping resistance	0	++	--
Durability	0	++	--
Wearing resistance	0	+	--
Fuel spillage resistance	0	+	0
0 : level or no change + : raised - : lowered Single and double symbols represent the extent of change.			



2.4.2. 5 The excellent performance of the SMA mixture makes it suitable for most climates, taking into account the variation of performance requirements with different environmental conditions. Some performances should be considered emphatically, such as high-temperature performance in hot climates, low-temperature crack resistance in cold climates and anti-aging capability against ultraviolet (UV) during plateaus.

2.4.2. 6 The SMA can be paved on runways, taxiways and apron taxiways. Under the conditions of high temperature or heavy traffic, reinforcing measures, such as polymer modified bitumen, high-modulus bitumen, lake asphalt and an anti-rutting agent, should be implemented at heavy load zones (i.e. holding positions, runway end taxiways and runway turn pads).

2.4.2. 7 In order to keep a good skid resistance of an SMA wearing course, hard stone (such as basalt, diabase, etc.) should be chosen as the SMA coarse aggregate. The aggregate crushing value should not be greater than 20 per cent, Los Angeles abrasion loss should not be greater than 30 per cent, and PSV should not be less than 42 per cent.

To bear heavy traffic, it is necessary to use modified bitumen in hot or cold climates. The reasonable dosage of modifier should be within the following scope: 4 to 6 per cent of bitumen weight for polymer modifier bitumen; asphalt content should be 5.7 to 6.0 per cent in cold climates, and 5.5 to 5.7 per cent in hot climates. Fibre stabilizers of SMA include cellulose, mineral and chemical fibres, which absorb bitumen to improve water resistance and anti-aging resistance of asphalt mixture. Usually fibre content of the SMA is 0.3 to 0.5 per cent of mixture weight. The recommended SMA mixture gradation is shown in Table A6-2.



Table A6-2.SMA mixture gradation requirements for aerodromes in China

Sieve size (mm)	Per cent passing (%)	
	SMA-16	SMA-13
19	100	
16	90-100	100
13.2	60-80	90-100
9.5	40-60	45-65
4.75	20-32	22-34
2.36	18-27	18-27
1.18	14-22	14-22
0.6	12-19	12-19
0.3	10-16	10-16
0.15	9-14	9-14
0.075	8-12	8-12



2.4.2. 8 The SMA mixture should meet the technical requirements listed in Table A6-3.

Table A6-3. SMA mixture property requirements for aerodromes in China

Index	Criteria
Marshall blows	75 on each face
Stability, minimum (kN)	6.0
Flow, 0.1 mm	20-50
Design air voids, %	3-5
Minimum VMA, %	17
Minimum asphalt content, %	5.5
Minimum dynamic stability Index 1, number /mm	when using modified asphalt: 3000 when using unmodified asphalt: 1500
Retained Marshall stability after submerged in water, minimum %	80
Minimum TSR, minimum %	75
Draindown (170°C, 1h), %, not greater than	0.15
Cantabro abrasion test (-0°C), %, not greater than	20

2.4.2. 9 For SMA-16, the optimum thickness after compaction is 6 cm (maximum is 7 cm and minimum is 5 cm). For SMA-13, optimum thickness after compaction is 5 cm (maximum is 6 cm and minimum is 4 cm). The SMA mixture should be made under high temperature conditions meeting the requirements shown in Table A6-4.





Table A6-4. Construction temperature of SMA pavement for aerodromes in China

Process	When using unmodified bitumen	When using modified bitumen		
		SBS	SBR	EVA or PE
Heating temperature of asphalt (°C)	150-160	160-165	160-165	150-160
Processing temperature of modified asphalt on site (°C)	-	165-170	-	160-165
Processing temperature of modified asphalt, maximum (°C)	-	175	-	175
Heating temperature of aggregate (°C)	185-195	190-200	200-210	180-190
Plant mixing temperature of SMA mixture (°C)	160-170	175-185	175-185	170-180
Temperature of SMA mixture, maximum (°C)	180	not greater than 190		
Storage temperature of SMA mixture (°C)	160	no more than 10°C under plant mixing		
Process	When using unmodified bitumen	When using modified bitumen		
		SBS	SBR	EVA or PE
		temperature		
Temperature of SMA mixture delivered to construction site, minimum (°C)	155	re than 15°C under plant mixing temperature		
Placement temperature, minimum (°C)	150	160		



Temperature during initial compaction, minimum (°C)	140	150
Temperature when compaction ceasing, minimum (°C)	110	130
Temperature at traffic opening, maximum (°C)	50	50

2.4.2. 10 When paving an SMA wearing course, the placement width of one paver should not be more than eight metres. In order to avoid the cold joint, six to seven pavers are arranged in echelon form for one-time paving full-width pavement on a 45 metre wide runway. Compaction should be accomplished with steel wheel rollers of a minimum weight of 12 tons. Rubber rollers are restricted since the rich bitumen tends to adhere to the rubber tires and causes excessive grinding of the mastic. However, when pavement temperature drops between 80°C to 100°C, it is permissible that rubber rollers are used for additional compaction to heal pavement voids and prevent water penetration.

## **2. 5 Runway contaminant removal techniques**

2.5. 1 Depending on the type and frequency of the air traffic on the runway, the runway pavement surface can accumulate contaminants such as oil, fuel and rubber deposits from aircraft tires. As the rubber deposits accumulate in the microtexture and macrotexture, runway surface friction can fall below the specification established by the State, especially when wet. The methods below are used in the removal of runway contaminants.

### *High pressure water*

2.5. 2 A series of high pressure water jets is aimed at the pavement to blast the contaminants from the surface. The contaminants can either be flushed off the runway or picked up by a vacuum truck. Water pressures can vary greatly depending on the contractor's equipment. As there are many parameters in high pressure water removal and the potential to damage the pavement from prolonged treatment, the treatment being particularly aggressive for cracked bituminous wearing courses, care must be taken in selecting a contractor with experience, demonstrated expertise and references.



*Chemical*

2.5.3 Chemical solvents have been used successfully for the removal of rubber on both concrete and asphalt runways. Effective chemicals used on concrete runways have a base of cresylic acid and a blend of benzene with a synthetic detergent for a wetting agent. Alkaline chemicals are generally used on asphalt pavements. As these chemicals are volatile and toxic in nature, extreme care must be exercised during and after the application. If the chemicals remain on the pavement too long, the painted areas and the surface could possibly be damaged. It is also important to properly dilute the chemical solvent that is washed off the pavement surface so the effluent will not harm surrounding vegetation, drainage systems or pollute nearby streams and wildlife habitats.

*High velocity impact*

2.5.4 Abrasive particles (usually steel shot) are sent at a very high velocity at the runway pavement surface, which can be adjusted to produce a desired surface texture. The abrasive is propelled mechanically from the peripheral tips of radial blades at a high speed, in a fan-like wheel. The entire operation can be environmentally clean as it is self-contained, collects and recycles the abrasive particles, and collects any loose contaminants and abrasive dust. The equipment can be self-contained and mobile and thus can be removed rapidly from the runway if required by airport operations. In any instance, a trial run should be carried out in a non-critical area in order to check the suitability of the equipment settings, the effectiveness of the cleaning, the absence of damage to the pavement surface texture, and the complete removal of the steel shot, including from any openings/joints/cracks, etc. in the pavement. It is critical to remove all steel shots to prevent FOD risks.

*Mechanical removal*

2.5.5 Mechanical grinding that employs the corrugating technique has been successfully used to remove heavy rubber deposits for both asphalt and concrete runways. This method (also known as thin milling) removes an in depth surface layer (3.2 mm to 4.8 mm) and improves the surface friction properties.

## 2.6 Mitigation of magnetic field distortions.

2.6.1 The presence of massive steel elements in or below the pavements and the use of magnetic devices to remove metallic elements from the surface have been causing local distortions to the Earth's magnetic field. Such distortions, also known as local magnetic anomalies, can interfere with the aircraft navigation systems and have been identified as a potential hazard for aircraft operations.

2.6.2 With reference to the Technical Instructions for the *safe Transport of Dangerous Goods by Air* (Doc 9284), and Packing Instructions 953 for goods UN 2807 — Magnetized masses, magnetic field local distortions deviating a compass 4.6 m above the pavement by more than two degrees (equivalent to 0.418 A/m or 0.00525 gauss) may have a significant effect on the direct-reading magnetic compasses or on the master compass detector units.

2.6.3 There are four possible methods of removing or attenuating the effect of airport infrastructure on the Earth's magnetic field:

- a) Each magnetic anomaly is individually demagnetized making it magnetically neutral. This is a short-term solution, as the magnetic anomaly would return over a period of a few years.
- b) Each individual magnetic anomaly has a permanent demagnetizing system installed with an individual magnetic field sensor to monitor the change in the magnetic effect of the anomaly over time, and have the demagnetizing system adjusted accordingly.
- c) A sheet of magnetically opaque material (e.g. magnetic shield foil) is placed over the area of the magnetic anomalies.
- d) Removal of the items, such as steel reinforced mesh or massive steel elements, that cause the magnetic anomalies.





### 3. PROTECTION OF ASPHALT PAVEMENTS

#### 3.1 Purpose

3.1.1 Maintenance includes preventive and any regular or recurring work necessary to preserve existing aerodrome pavements in good condition. Replacing individual parts and mending portions of a pavement are considered minor repair. Typical preventive and regular or recurring pavement maintenance includes: routine cleaning, filling and/or sealing of cracks; patching pavement; seal coating; grading pavement edges; maintaining pavement drainage systems; and restoring pavement markings. Timely maintenance and repair of pavements is essential in maintaining adequate load-carrying capacity, preserving sufficient surface friction under all weather conditions and providing good ride quality necessary for the safe operation of aircraft, and minimizing the potential for FOD.

3.1.2 This chapter describes the protection of asphalt pavements from two types of pavement distress: weathering and ravelling from environmental oxidation; and oil (fuel and lubricants) spillage, which can be prevented or minimized by the proactive engagement of the aerodrome and staff in protecting the asphalt pavement surface.

#### 3.2 Weathering and ravelling from environmental oxidation

3.2.1 Weathering and ravelling of the pavement surface is caused by oxidation due to exposure to the environment, which leads to the problem of pavement produced FOD. Locations of concern are all pavement where aircraft traffic occurs (runways, taxiways and aprons) as well as pavement immediately adjacent, such as shoulders and vehicle traffic lanes.

3.2.2 Seventy to ninety per cent of asphalt pavement deterioration and failure are the result of exposure to the environment and degradation of the asphalt binder (oxidation). Oxidation occurs when the pavement surface is exposed to oxygen in the air and water, which attacks the asphalt binder causing it to harden and become brittle or “breaks down”. Ultraviolet rays from the sun exacerbate this process, which is often referred to as “ageing”.





3.2.3 Asphalt (also known as bitumen) comes from the left over fractions in the crude oil refining process. Technological advances in the refining process extract and separate increasingly more high value resins and oils, leaving less of these resins and oils for asphalt. Therefore, left over fractions are fortified and designed to meet necessary physical properties for asphalt binders, consequently performing in a reduced capacity when exposed to environmental effects.

3.2.4 The asphalt binder (the “glue” that binds the aggregate together) breaks down by oxidation from the weather, resulting in pavement surface deterioration. The aggregate literally comes “unglued”; first the fine aggregate, which is considered “weathering” distress, then the coarse aggregate, which is considered “ravelling” distress. These distresses produce loose aggregate and pieces of pavement, which is considered pavement generated FOD.

*Treatment*

3.2.5 This problem can be substantially reduced if the oxygen in the air and water are not allowed to come in contact with the asphalt binder in the pavement surface. Protective coatings have accordingly been developed to provide a barrier between the environment and the pavement surface, which assists to minimize the effects of oxidation.

*Protective coatings*

3.2.6 Liquid coatings (“seal coat”) to assist against oxidation have been developed by incorporating at least 20 per cent natural asphalt (known as gilsonite, uintaite, rock asphalt, etc.) with refined asphalt, which is used as an emulsified asphalt sealer; typically described as emulsified asphalt seal coat. This material should be applied by using asphalt distributor equipment. In small areas, the material can be applied by using hand sprayers or by pouring it on the surface and spreading it using squeegees or brushes.

3.2.7 The emulsified refined asphalt can be substituted with a solvent-based asphalt by incorporating at least 40 per cent natural asphalt.





*Note.— Local environmental regulations should be taken into consideration if solvent-based asphalt products are considered to be used.*

3.2. 8 Other modified asphalt emulsified seal coats, such as a polymer modified without incorporating natural asphalt have also been used; however, to achieve desirable results, this material must be applied using at least two applications, the second coat being applied immediately after the first coat is dry to the touch (and the third, if used, after the second coat is dry to the touch).

3.2. 9 Coating materials in emulsion form can be extended and premixed with fine aggregate to form a slurry and applied as a slurry seal.

*Protection gains and concerns*

3.2. 10 Seal coats will reduce skid resistance immediately when applied but will improve and typically obtain acceptable friction test results within the first 24 to 48 hours, which needs to be considered when the application is on a runway or high-speed exit taxiway. Solvent-based treatments will typically obtain acceptable friction test results within two to three hours. Skid resistance will continue to improve and obtain similar skid resistance as that prior to the application, typically within about one week to three months.

3.2. 11 For the application of a seal coat surface treatment on the runway and high-speed exit taxiway, the application of a suitable aggregate to maintain initial adequate surface friction for the first few hours or days must be included. When aggregate is to be applied, it must be spread by an asphalt distributor truck equipped with an aggregate spreader mounted to the distributor truck that can apply sand to the emulsion in a single pass operation without driving through wet emulsion.

3.2. 12 Application rates of seal coats will vary from location to location and with various pavement conditions, age etc. Therefore, testing in areas or sections for each location should be performed to provide the contractor and the engineer an opportunity to determine the quality of the mixture in place, the quantity actually needed, as well as the performance of the equipment. This is also used to document skid resistance acceptance if the application is to be on a runway or high-speed exit taxiway.





3.2. 13 The decision to apply a treatment, or not, particularly to a runway, is a balance between the risk of adversely impacting skid resistance versus the risk of FOD being generated from the surface. Factors to consider include the existing asphalt surface condition, climactic conditions, aircraft aborted take-off distance required versus accelerate-stop distance available (ASDA) and timing of asphalt resurfacing. The residual from past multiple treatments, even many years after their application, must be considered as they may contribute to friction concerns.

### **3. 3 Oil spillage distress from fuel and lubricants spillage**

3.3. 1 Fuels and lubricants contain solvents that will effectively dissolve the asphalt binder and temporarily reduce its hardness when in contact with an asphalt pavement surface. Locations of concern are those areas where aircraft are regularly fuelled, parked or serviced. The areas for landing and taxiing operations will not be of concern, since even spillages due to aircraft accidents will be minimized by clean-up and a single spillage will cure without permanent damage.

3.3. 2 The severity of problems is related to the degree of exposure to the penetrating solvents, therefore, concern is with the frequency of spillage repeated on one location, the length of time the spilled fuel or oil remains on or in the pavement, and the location and extent of spillage on the pavement. A single spillage of jet fuel and even several spillages in the same location, when there is time for evaporation and curing between spillages, do not normally have a significant adverse effect on the pavement. However, some staining and a tender (temporarily softened) pavement are to be expected while the solvents evaporate and the asphalt re-hardens.

3.3. 3 Spillages can result from routine operations such as engine shutdown, fuel tank sediment draining, consistent use of solvents for cleaning of engine or hydraulic system elements, etc. More commonly spillage is the result of fuel handling operations, of spilled oil or hydraulic fluid, or accumulated drippings from engine oil leakage or mishandling.

3.3. 4 In areas where spillage occurs repeatedly or spilled fuel or oil remains for long periods of time on the pavement, the solvent action softens the asphalt and reduces adhesion to the surface aggregate.





The result of the spillage can be shoving of the asphalt mix, tire tread printing, tracking of asphalt to adjacent areas, production of loose material, and pavement abrasion also producing loose material on the pavement surface. In maintenance and work areas, asphalt and grit picked up by tools, shoes and clothing can be transferred to mechanical systems.

*Treatment*

3.3.5 The best treatment is avoidance of spillage, which is possible in many cases of operational spillage and some accidental spillage. Fuel tank sediment drainage can be caught and need not be allowed on the pavement. Drip pans can be used for oil drip locations and for bleeding or servicing of hydraulic systems. Trays may be practical to catch engine shutdown spillage or small quantities of refuelling spillage.

3.3.6 Removal of the spilled fuel or oil and reduction of exposure through clean-up is the next aspect of treatment. There are a number of ways that spilled fuel or oil can be cleaned off and removed from the pavement, ranging from wiping up a small spill with detergents to using a vacuuming process using suitable equipment, which can be used to remove spilled fuel and possibly some fuel recovery, to using absorbent materials, which can also pick up fuel and oil with suitable arrangement for disposal.

*Note.— Local environmental regulations should be taken into consideration for both removal and disposal of contaminants. Protective coatings*

3.3.7 Spillage problems cannot develop if spilled fuel or oil is not allowed to come in contact with the asphalt in the pavement surface. Protective coatings have accordingly been developed to provide a barrier between the fuel or oil and the pavement, which assists to minimize the effects by the spilled fuel or oil.

3.3.8 Thin overlays of fuel-resistant hot mix asphalt pavement or other materials that may not be affected by spillage can be applied to protect asphalt pavements. Conventional construction methods are applicable unless some very unconventional materials are employed.





3.3. 9 Some States or local vicinities may still allow a coal tar pitch liquid coating, which is used as an emulsified sealer and is the basic ingredient in various commercially offered “coal tar” sealers. Coating materials in emulsion form can be extended and premixed with fine aggregate to form a slurry and applied as a slurry seal.

*Note.— Local environmental regulations or prohibitions should be taken into consideration if coal tar products are considered to be used on pavement surfaces.*

*Protection gains and concerns*

3.3. 10 Durability and wear can vary with the materials and applications, the surface cleaning and preparation, maintenance of the protective coating and of course exposure to spillage and traffic.

3.3. 11 For coal tar-based liquid coating, some material formulations and application methods, either individually or in concert, can result in imperfect coverage by the seal coating. Bubbles can exist at application leaving holes in the coating, or bubbles can form beneath a coating after cure and on “breaking” leaving holes. Coal tar coatings can shrink

and crack. Improper surface cleaning can result in a poor bond and peeling of the coating. Pre-existing cracks in the coated pavement will tend to come through the protective surface coating.

3.3. 12 When fuel can gain access through holes or cracks in the coating, through peeled areas, or through cracks reflected from the lower pavement, or when fuel saturated pavement has not been removed and is covered by the coating, conditions are worsened rather than improved by the seal, since, in addition to not preventing access of the spilled fuel or oil to the asphalt, the coating greatly inhibits the evaporation and curing-out of the spillage.

3.3. 13 Overlays and slurry seals give spillage protection and are not subject to bubble holes, peeling or wear.





Coal tar slurry seals are subject to shrinkage, cracking and to crack reflection from underlying pavements. Overlays described previously do not have these inherent issues as long as they are properly compacted and have a void content of about two per cent.

#### **4. construction of asphalt overlay during operations closures**

##### **4.1.1 Introduction**

The volume and frequency of operations at many airports makes it virtually mandatory to repair movement areas portion by portion during short periods of traffic operation closure. The purpose of this chapter is to provide guidance for the procedures to be used by those associated with such short-term repairs, namely, the airport manager, project manager, designer, inspector, material testing technicians and contractors, to ensure that the work is carried out safely and most efficiently without loss of revenues, inconvenience to passengers or delays to the air traffic systems.

##### **4.2 Airport authority's role**

###### *Project coordination*

4.2.1 Off-peak construction is, by its very nature, a highly visible project requiring close coordination with all elements of the airport during planning and design and virtually daily during construction. Once a runway paving project has been identified by the airport, it is important that the nominees of the airport authority, users and CARC meet to discuss the manner in which construction is to be implemented. The following key personnel should be in attendance at all planning meetings:

- a) from the airport authority: the project manager, the operations, planning, engineering and maintenance directors;
- b) from the airlines: local station managers and head office representatives, where appropriate;  
and





- c) from the civil aviation authority: representatives from air traffic services and aeronautical information services.

4.2.2 The agenda should include:

- a) determination of working hours. Since time is of the essence in off-peak construction, the contractor should be given as much time as possible to overlay the pavement during each work period. A period of eight hours is generally considered suitable. Work should be scheduled for a time period that will displace the least amount of scheduled flights. The selection of a specific time period should be developed and coordinated with airline and other representatives during the initial planning meetings.

Early identification of the hours will allow the airlines to adjust future schedules, as needed, to meet construction demands. It is essential that the runway be opened and closed at the designated time without exception, as airline flight schedules, as well as the contractor's schedules, will be predicated on the availability of the runway at the designated time;

- b) identification of operational factors during construction and establishment of acceptable criteria should include:
  - 1. designation of work areas;
  - 2. aircraft operations;
  - 3. affected navigation aids (visual and non-visual aids);
  - 4. security requirements and truck haul routes;
  - 5. inspection and requirements to open the area for operational use;
  - 6. placement and removal of construction barricades;
  - 7. temporary aerodrome pavement marking and signing;





- 8. anticipated days of the week that construction will take place; and
- 9. issuance of NOTAM and advisories;
- c) lines of communication and coordination elements. It is essential that the project manager be the only person to conduct coordination of the pavement project. The methods and lines of communication should be discussed for determining the availability of the runway at the start of each work period and the condition of the runway prior to opening it for operations;
- d) special aspects of construction including temporary ramps and other details as described herein;
- e) contingency plan in case of abnormal failure or an unexpected disaster;
- f) coordination of necessary pre-investigation measures for determining the thickness and quality of the respective pavement sample; and
- g) ensure that the design is carried out by competent staff, including identification of tasks and workflow and the production of a quality assurance plan.

*Role of project manager and resident engineer*

4.2.3 It is essential that the airport authority select a qualified project manager to oversee all phases of the project, from planning through final inspection of the completed work. The qualifications of the project manager could be assessed via international organizations. This individual should be experienced in design and management of aerodrome pavement construction projects and be familiar with the operations of the airport. The project manager should be the final authority on all technical aspects of the project and be responsible for its coordination with airport operations. All contact with any element of the airport authority should be made only by the project manager, so as to ensure continuity and proper coordination with all elements of aerodrome operations. Responsibilities should include:

- a) planning and design;



1. establishment of clear and concise lines of communications;
  2. participation as a member of the design engineer's selection team;
  3. coordination of project design to meet applicable budget constraints;
  4. coordination of airport and airlines with regard to design review, including designated working hours, aircraft operational requirements, technical reviews and the establishment of procedures for coordinating all work; and
  5. chairing of all meetings pertaining to the project;
- b) construction;
1. complete management of construction with adequate number of inspectors to observe and document work by the contractor;
  2. checking with the weather bureau, airport operations and air traffic control prior to starting construction and confirming with the contractor's superintendent to verify if weather and air traffic conditions will allow work to proceed as scheduled;
  3. conferring with the contractor's project superintendent daily and agreeing on how much work to attempt, to ensure the opening of the runway promptly at the specified time each morning. This is especially applicable in areas where pavement repair and replacement are to take place; and
  4. conducting an inspection with airport operations of the work area before opening it to aircraft traffic, to ensure that all pavement surfaces have been swept clean, temporary ramps are properly constructed and marking is available for aircraft to operate safely.



The project manager has to monitor during the entire construction that country-specific regulations and minimum standards are met (i.e. in Germany, ZTV-Asphalt, Chapter 5 or ZTV-Concrete, Chapter 3.5 or United States practice mentioned in Chapter 4 of this Guidance material).

4.2. 4 The designation of a resident engineer, preferably a civil engineer, will be of great benefit to the project and of great assistance to the project manager. Duties of the resident engineer should include:

- a) preparation of documentation on the work executed during each work period;
- b) ensuring all tests are performed and results obtained from each work period;
- c) scheduling of inspection to occur each work period;
- d) observing contract specifications compliance and reporting of any discrepancies to the project manager and the contractor; and
- e) maintaining a construction diary.

#### *Testing requirements*

4.2. 5 At the end of each work phase and prior to the start of operation, an acceptance test must be carried out and the results must be checked before the start of operations. These procedures normally will require additional personnel to ensure that tests are performed correctly and on time.

4.2. 6 The review of the quality of raw materials is carried out according to country-specific regulations. Here, minimum standards should be respected. (i.e. in Germany, TL-asphalt or TL-concrete). For the installation of fasthardening concrete and monitoring by means of sensors (maturity computer), refer to Dutch standard NEN 5970.





*Inspection requirements*

4.2. 7 One of the most important aspects of successful completion of any kind of paving project is the amount and quality of inspections performed. Since the airport accepts beneficial occupancy each time the runway is open to traffic, acceptance testing must take place each work period. In addition to the project manager and resident engineer, the following personnel are recommended, as a minimum, to observe compliance with specifications:

- a) **Material plant inspector (asphalt, concrete).** A material plant inspector with a helper whose primary duty is to perform quality control tests, including aggregate gradation, hot bin samples and Marshall tests (e.g. the taking of samples from the gas reservoir and the Marshall tests), slump tests, reading a maturity computer, and compressive strength test.
- b) **Inspector for paver or manual installation.** One inspector per machine and/or hand box. There should be two paving inspectors for each paving machine. Their duties should include collection of delivery tickets, checking temperatures of delivered material, inspection of grade, control methods, and inspection of asphalt or concrete lay-down techniques and joint construction smoothness.

*Note.— It is recommended to carry out a field test run in advance of the construction work to test the installation conditions and the material.*

- c) **Compaction inspector.** The compaction inspector should be responsible for observing proper sequencing of rollers and for working with a field density meter to provide the contractor with optimum compaction information.
- d) **Survey crew.** Finished grade information from each work period is essential to ensuring a quality job. An independent registered surveyor and crew should record levels of the completed pavement at intervals of at least 8 m longitudinally and 4 m transversely, and report the results to the project manager at the completion of each work period.





- e) **Pavement repair inspector.** The pavement repair inspector shall be responsible for inspecting all pavement repairs and surface preparation prior to paving.
- f) **Electrical inspector.** The electrical inspector ensures compliance with specifications.

### 4.3 Design considerations

4.3.1 Plans and specifications for pavement repair and overlay during off-peak periods should be presented in such detail as to allow ready determination of the limits of pavement repair, finish grades and depths of overlay. Plans and specifications are to be used for each work period by the contractor and inspection personnel, and should be clear and precise in every detail.

#### *Pavement survey*

4.3.2 A complete system of benchmarks must be set on the side of the runway or taxiway to permit a ready reference during cross-sectioning operations. The benchmarks should be set at approximately 125m intervals. Pavement cross-sectioning should be performed approximately at 8 m intervals longitudinally, and 4 m intervals transversely. Extreme care should be exercised in level operations, since the elevations are to be used in determining the depth of asphalt overlay. The designer should not consider utilizing grade information from previous drawings or surveys that were used during the winter months, as it has been shown that elevations can vary from one season to the next. This is especially critical for single lift asphalt overlays.

4.3.3 After finish grades and the transverse slope of the runway are determined, a tabulation of grades should be included in the plans for the contractor to use in bidding the project and for the establishment of an erected string line. The tabulation of grades should include a column showing existing runway elevation, a column showing the finish overlay grade and a column showing the depth of overlay. Grades should be shown longitudinally every 8 m and transversely every 4 m. This item is considered essential in the preparation of plans for contracting off-peak construction.



Special details

4.3.4 Details pertaining to the items below should be included in the plans.

4.3.4.1 **Temporary ramps.** At the end of each hot mix asphalt concrete overlay work period, it will be necessary to construct a ramp to provide a transition from the new course of overlay to the existing pavement. The only exception to construction of a ramp is when the depth of the overlay is 4 cm or less. In multiple lift overlays, these transitions should be no closer than 150 m to one another. As far as possible, the overlay should proceed from one end of the runway toward the other end in the same direction as predominant aircraft operations so that most aircraft encounter a downward ramp slope. See Figures A6-13 and A6-14.

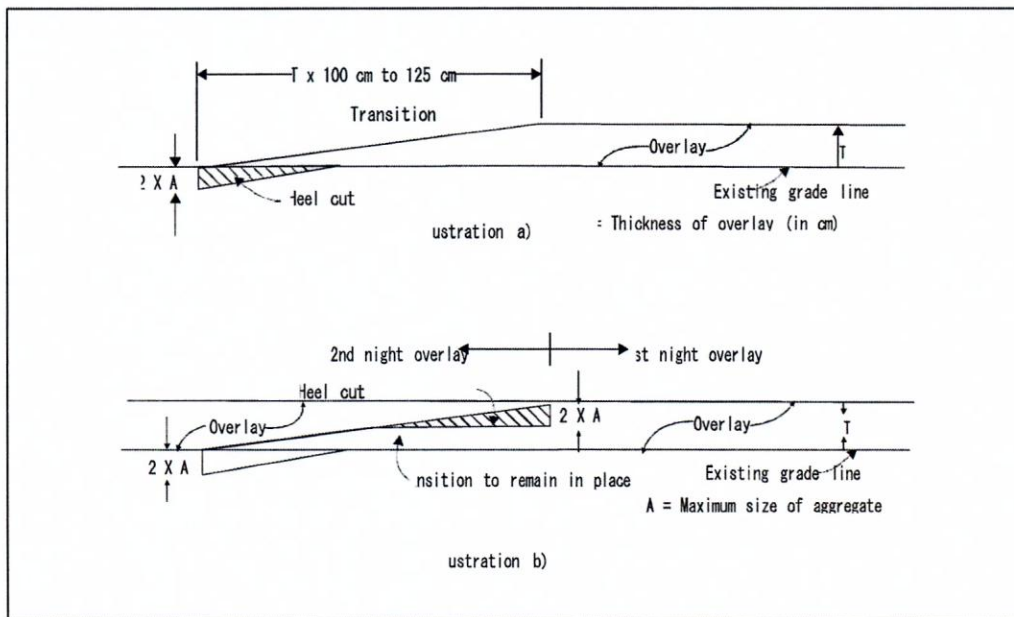

Figure A6-13. Temporary ramp construction with cold planing machine



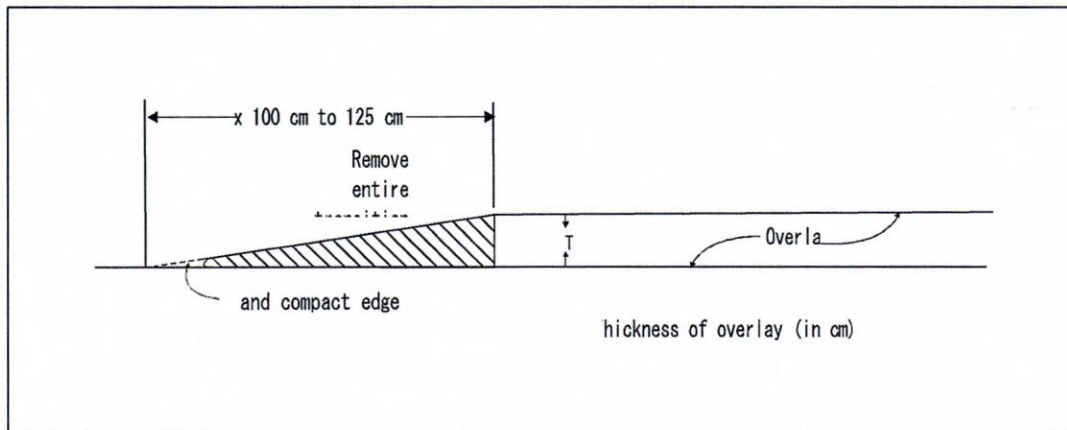

Figure A6-14. Temporary ramp construction without cold planing machine

4.3.4. 2 **In-pavement lighting.** Details depicting the removal and reinstallation of in-pavement lighting are to be included on the plans where applicable. The details should depict the removal of the light fixture and extension ring, placement of a target plate over the light base, filling the hole with hot mix dense graded asphalt until overlay operations are complete, accurate survey location information, core drilling with a 10 cm core to locate the centre of the target plate, and final coring with an appropriate sized core machine. The light and new extension ring can then be installed to the proper elevation.

4.3.4. 3 **Runway markings.** During the course of off-peak construction of a runway overlay, it has been found acceptable, if properly covered by a NOTAM, to mark only the centreline stripes and the runway designation numbers on the new pavement until the final asphalt lift has been completed and final striping can then be performed. In some cases where cold planing of the surface or multiple lift overlays are used, as many as three consecutive centreline stripes may be omitted to enhance the bond between layers.

4.3.4. 4 **Construction with concrete:** In addition to the renewal of the pavement by asphalt, concrete material can be used. Through the development of concrete mix, fast-hardening concrete manufacturing is now applicable. For this purpose, an advance concrete formulation research should take place to enable complete construction within the available timeframe (minimum ten hours). During installation,





the required minimum compressive strength can be determined by means of sensors (maturity computer).

4.3.4. 5 **Scope of the pre-investigation:** The pre-investigation of structure and sublayer soil should include in the parameters sustainability, forestry sensitivity and water-sensitivity. The extent depends on the country-specific requirements (for example, in Europe, Euro Code 7). It is also recommended to perform a PCR calculation ahead of the Pavement repair.

